

SOLGUL

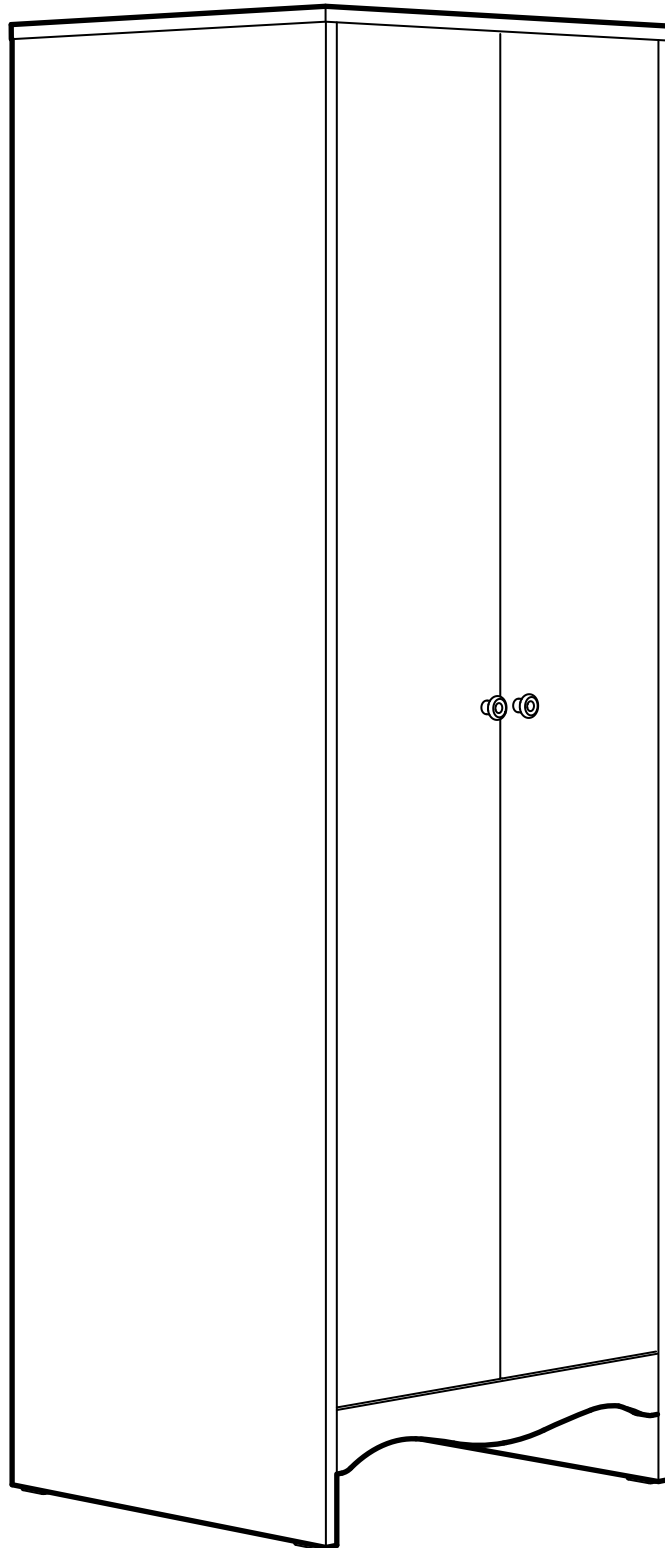

Design and Quality
IKEA of Sweden

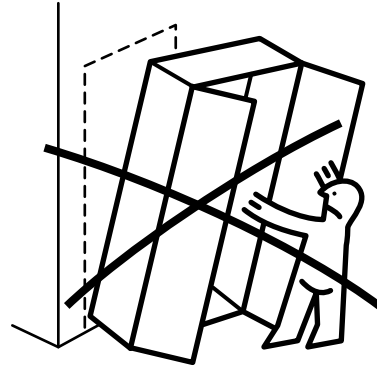
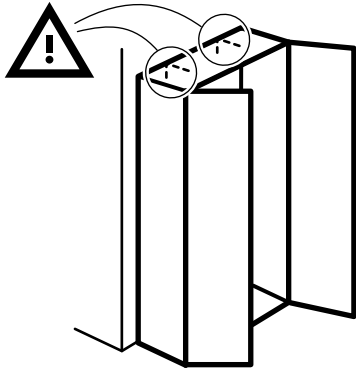

WARNING

Serious or fatal crushing injuries can occur from furniture tip-over. ALWAYS secure this furniture to the wall using tip-over restraints. To further reduce the risk of serious injury and death from tip-overs:

- Place heaviest items in the lower drawer.
- Do not set TVs or other heavy objects on top of this product.
- Never let children climb or hang on drawers, doors, or shelves.

ATTENTION

Risque de blessures graves ou mortelles en cas de basculement du meuble. TOUJOURS fixer ce meuble au mur à l'aide des fixations anti-basculement. Pour encore réduire les risques de blessures graves ou mortelles dus au basculement du meuble :

- Placer les objets les plus lourds dans le tiroir du bas.
- Ne pas poser de TV ou d'objet lourd sur le dessus de ce produit.
- Ne jamais laisser les enfants grimper ou s'accrocher aux tiroirs, portes ou tablettes.

ADVERTENCIA

Si el mueble vuelca, puede provocar lesiones muy graves e incluso mortales. Fija SIEMPRE este mueble a la pared utilizando los accesorios antivuelco. Para reducir aún más el riesgo de lesiones graves o incluso mortales causadas por el vuelco del mueble:

- Guarda los objetos más pesados en el cajón inferior.
- No pongas un TV u otros objetos pesados encima de este producto.
- Evita que los niños suban encima del mueble o se cuelguen de los cajones, las puertas o los estantes.

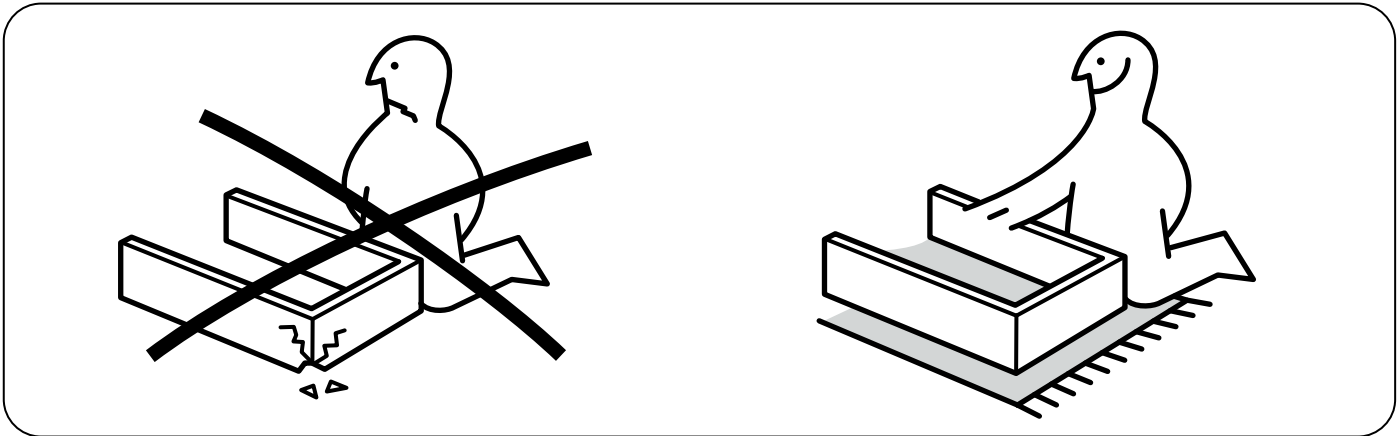
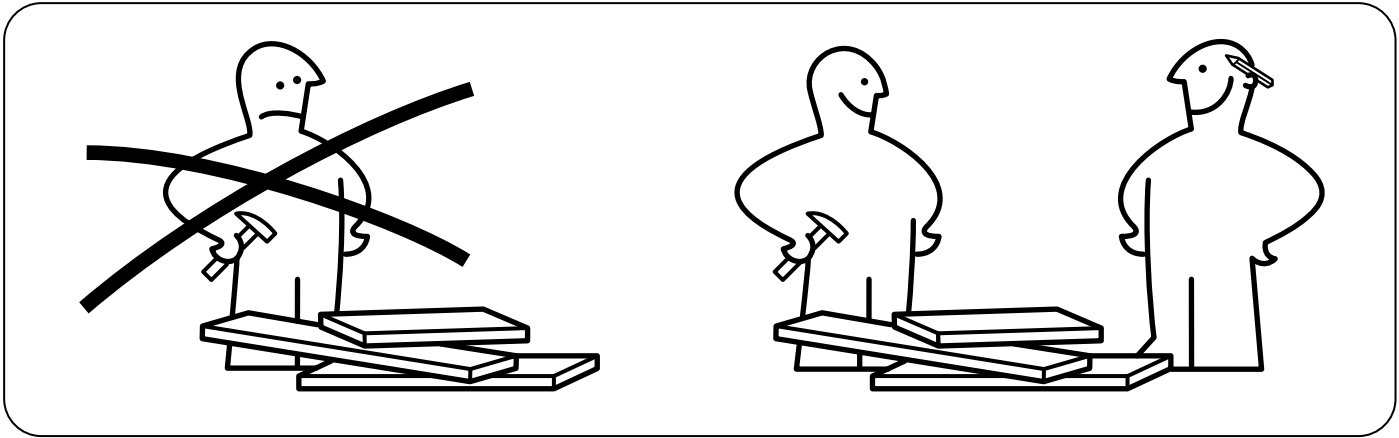
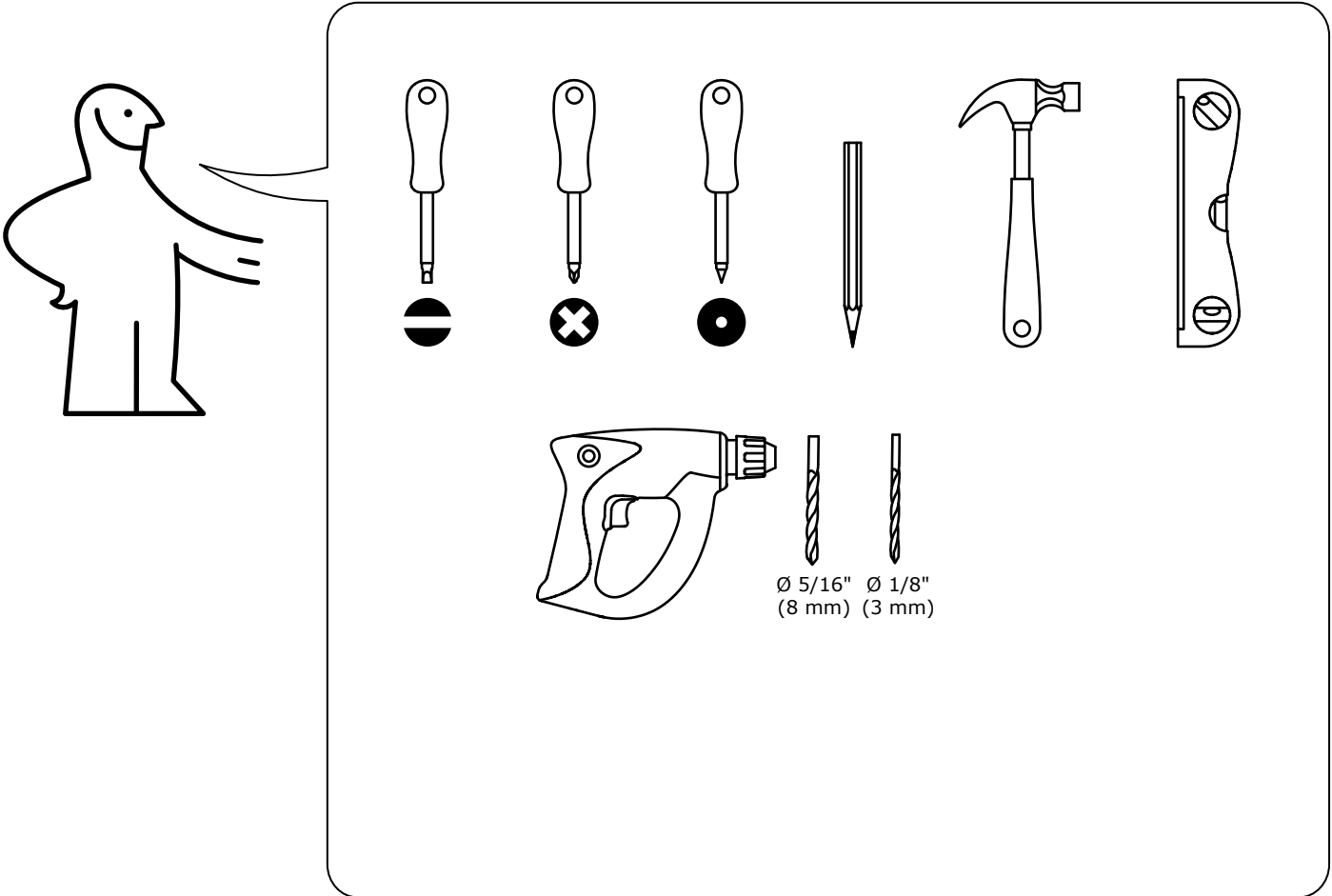

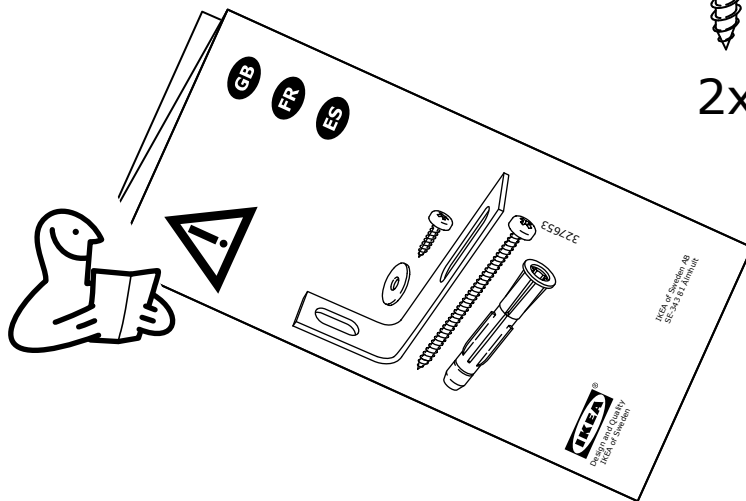
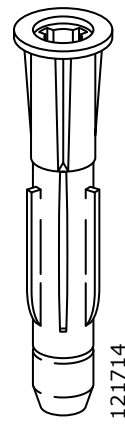
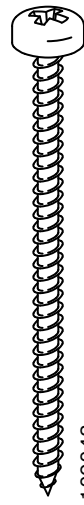
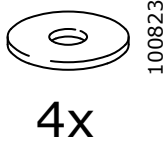
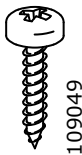
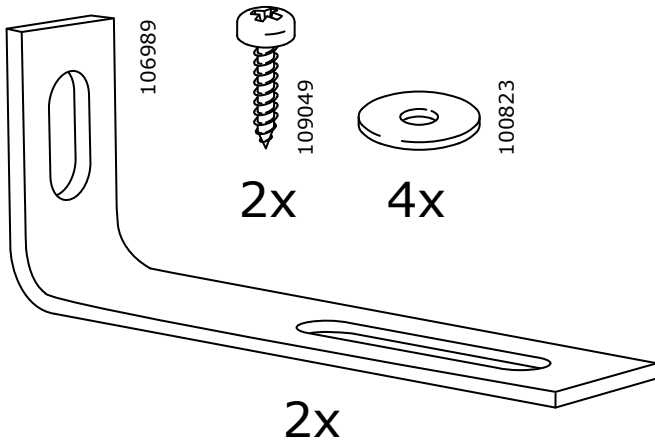
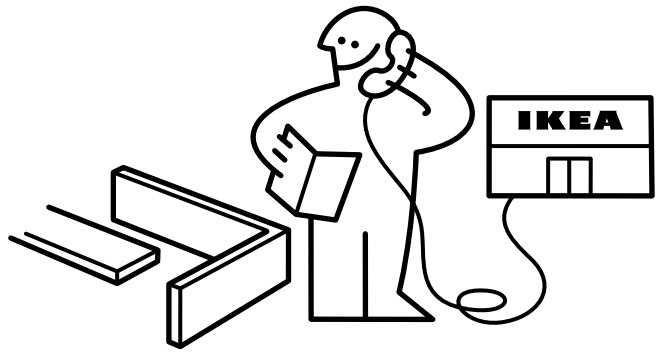
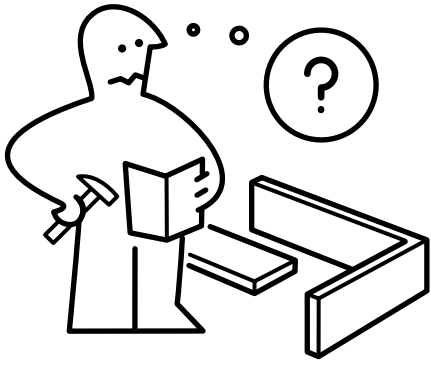

327653

1

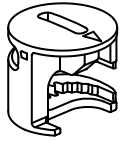

118137

8x

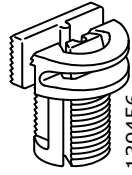

139456

8x

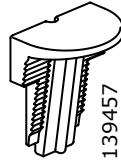

139457

8x

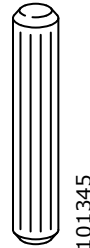

101345

10x

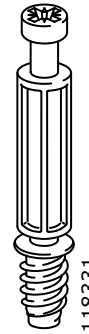

118331

8x

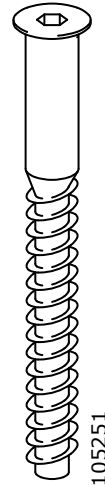

105251

4x

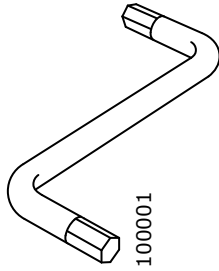

100001

1x

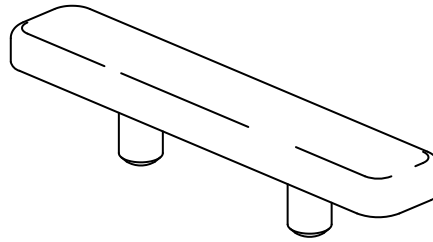

153548

4x

2



113287

2x



116637

8x



115339

4x

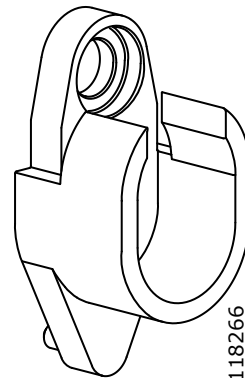

118266

2x

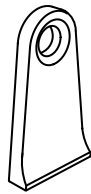

119985

4x

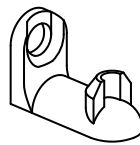

114929

4x

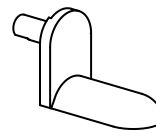

113301

4x

3

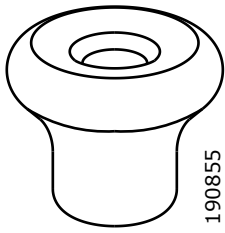

190855

2x

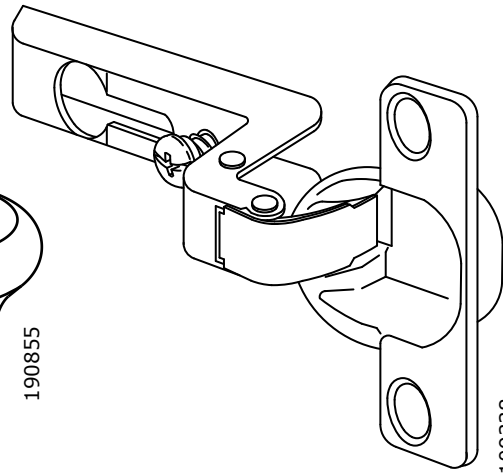

109338

6x

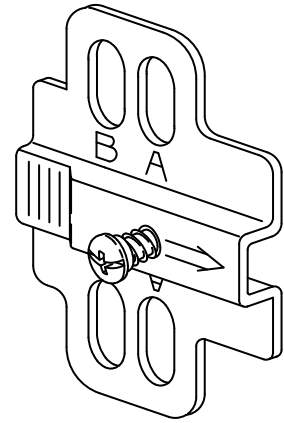

109221

6x



113287

24x

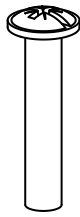

115981

2x



112891

2x

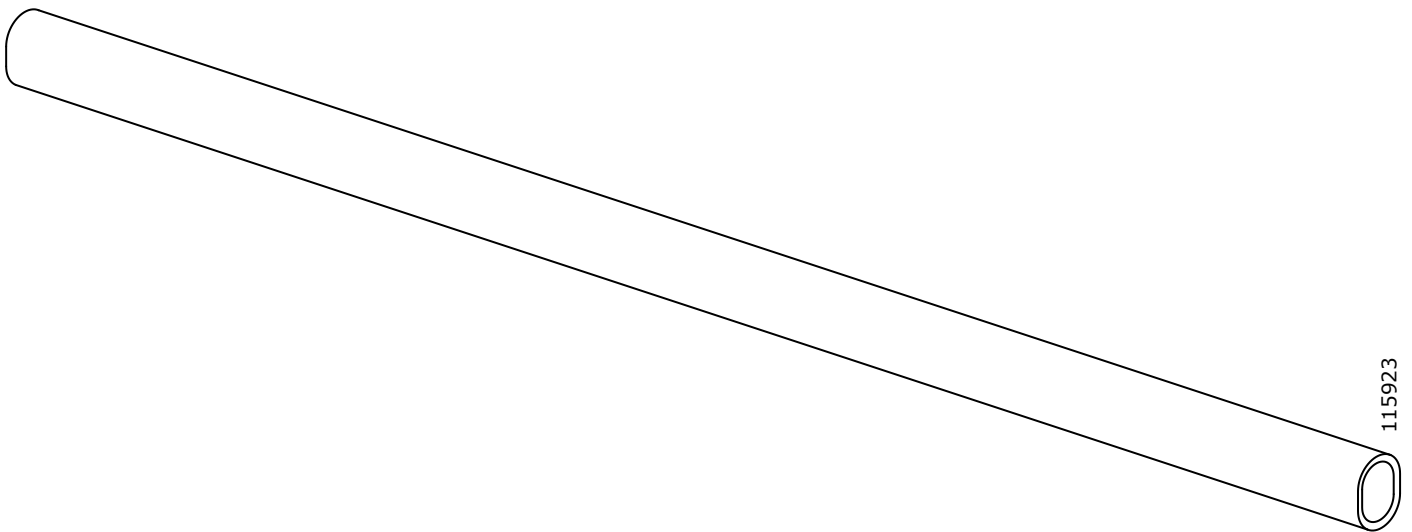

115923

1x

1

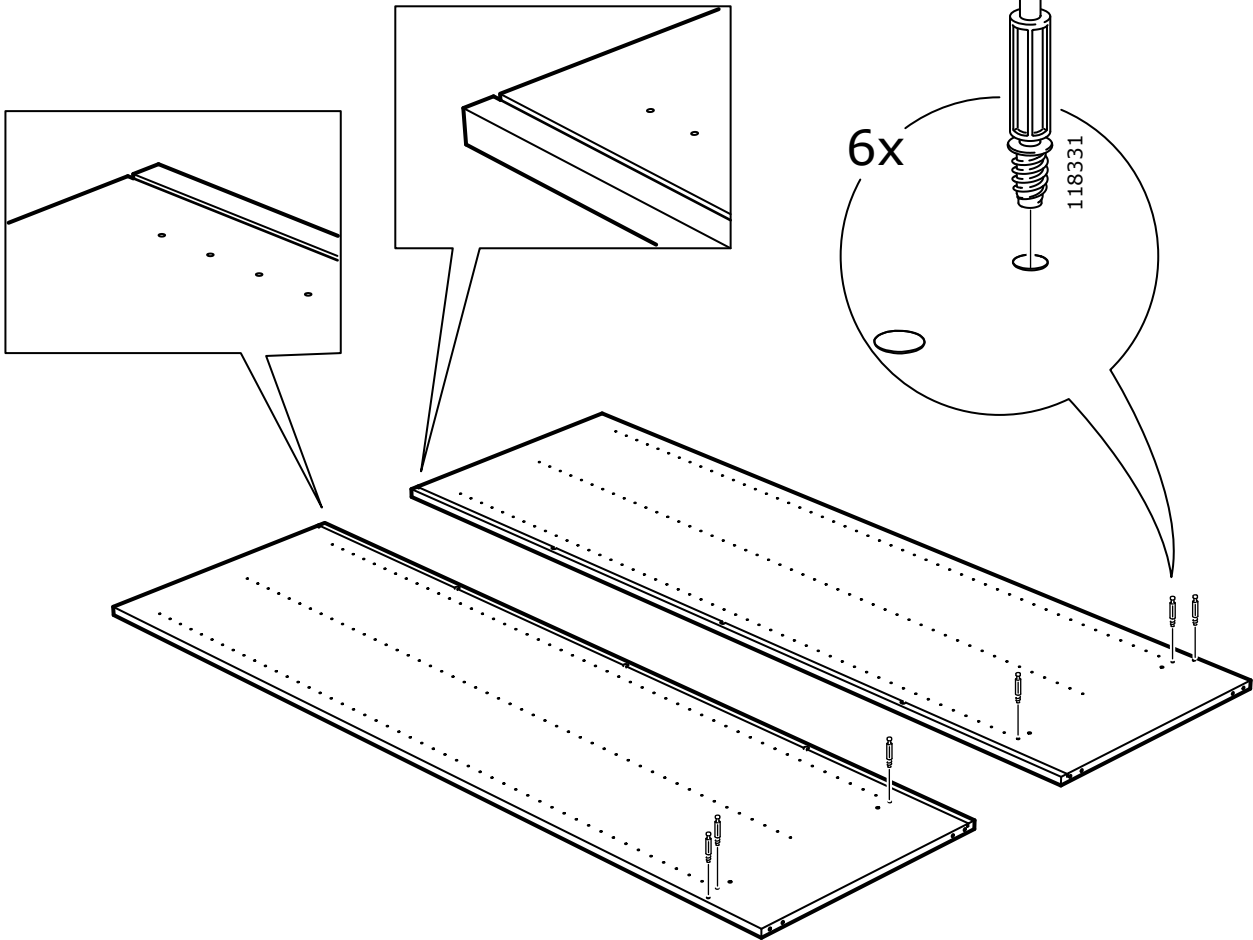
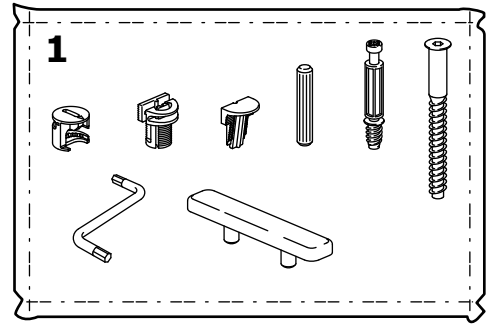
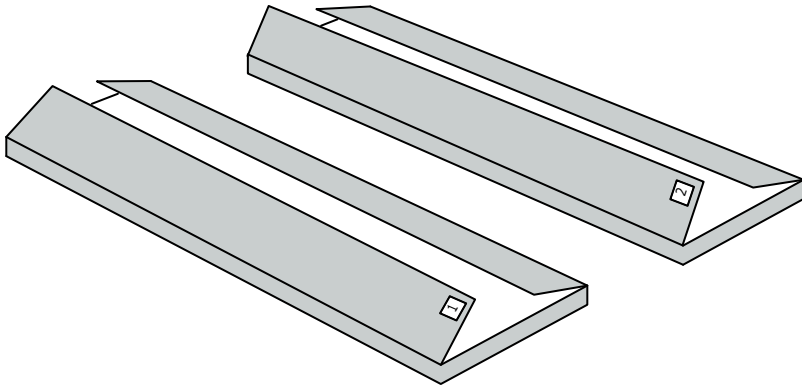

2

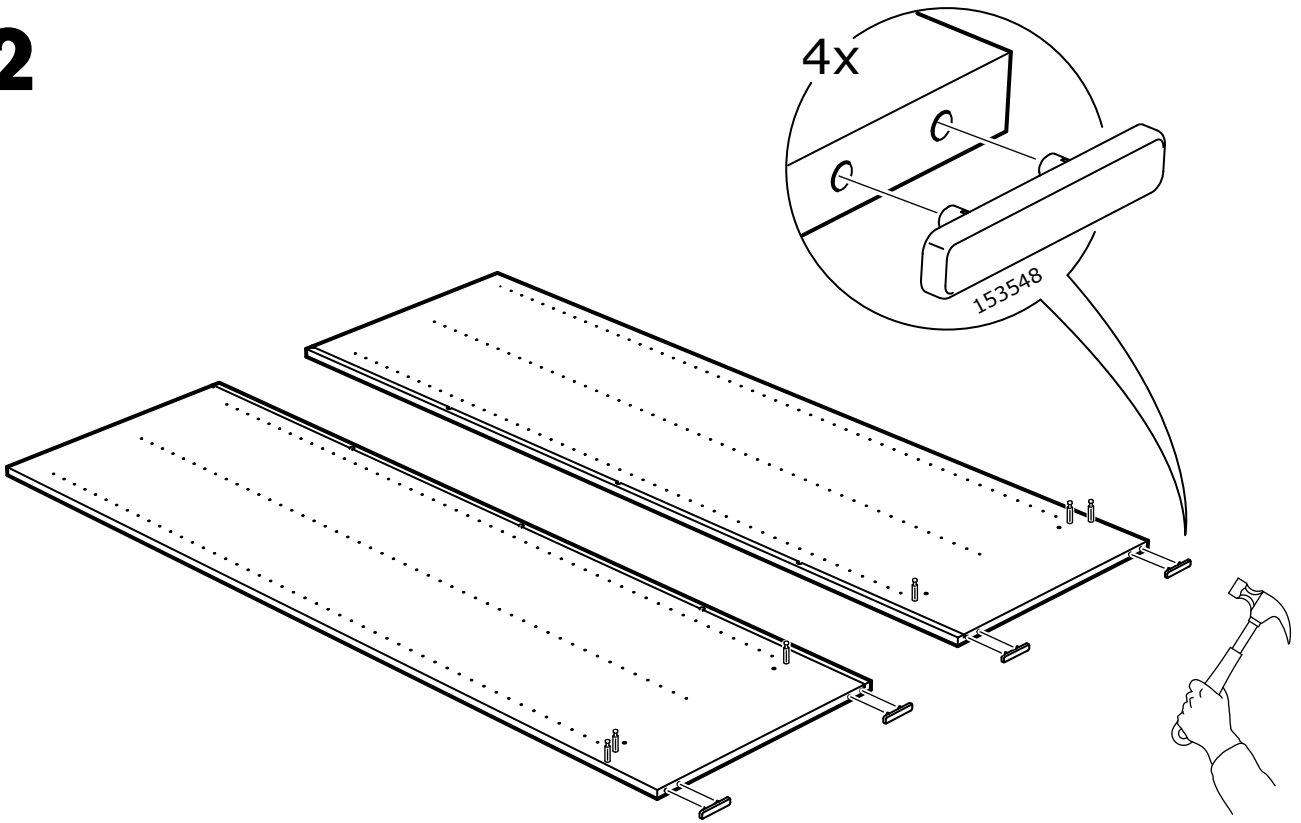

3

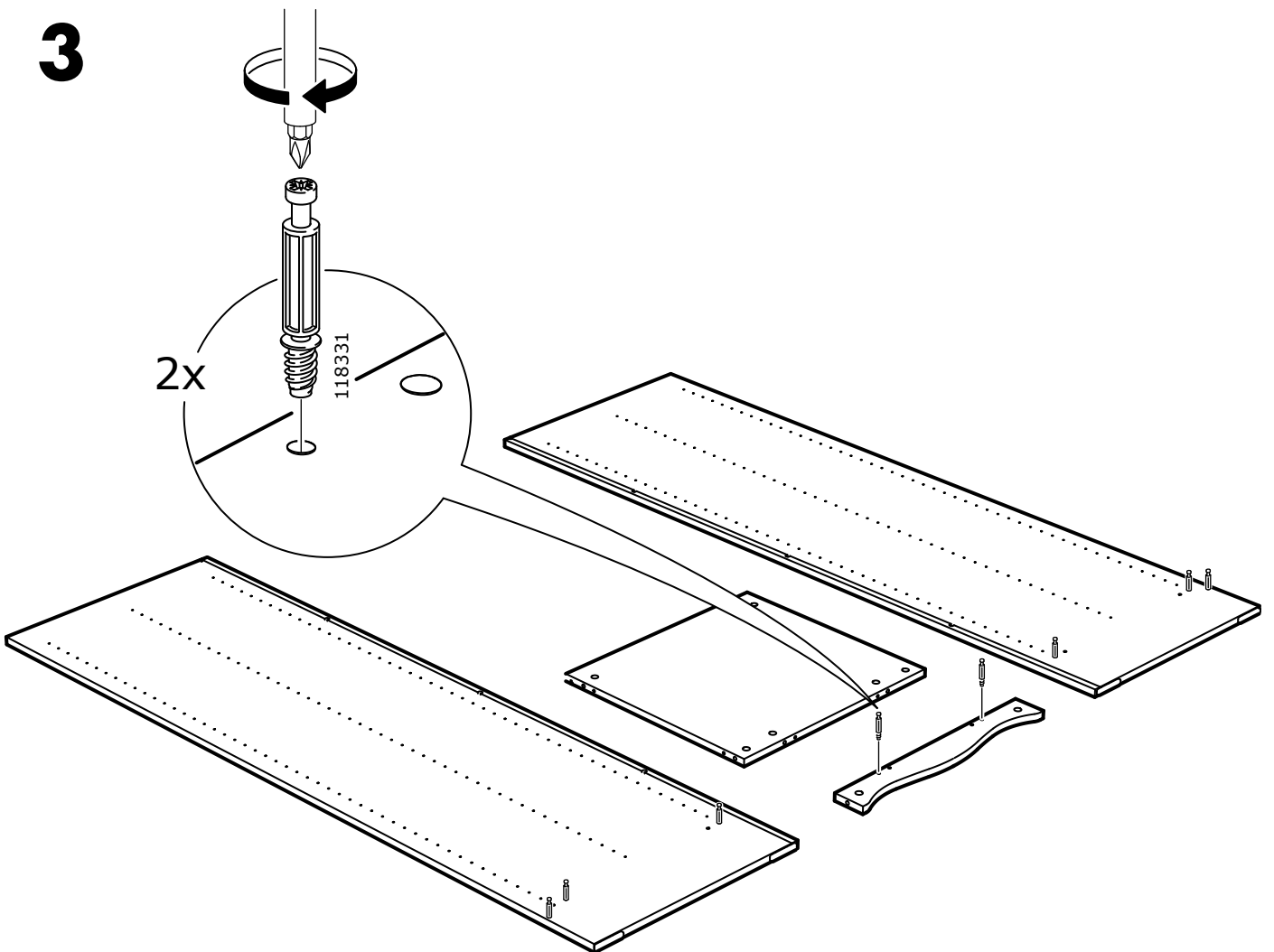

4

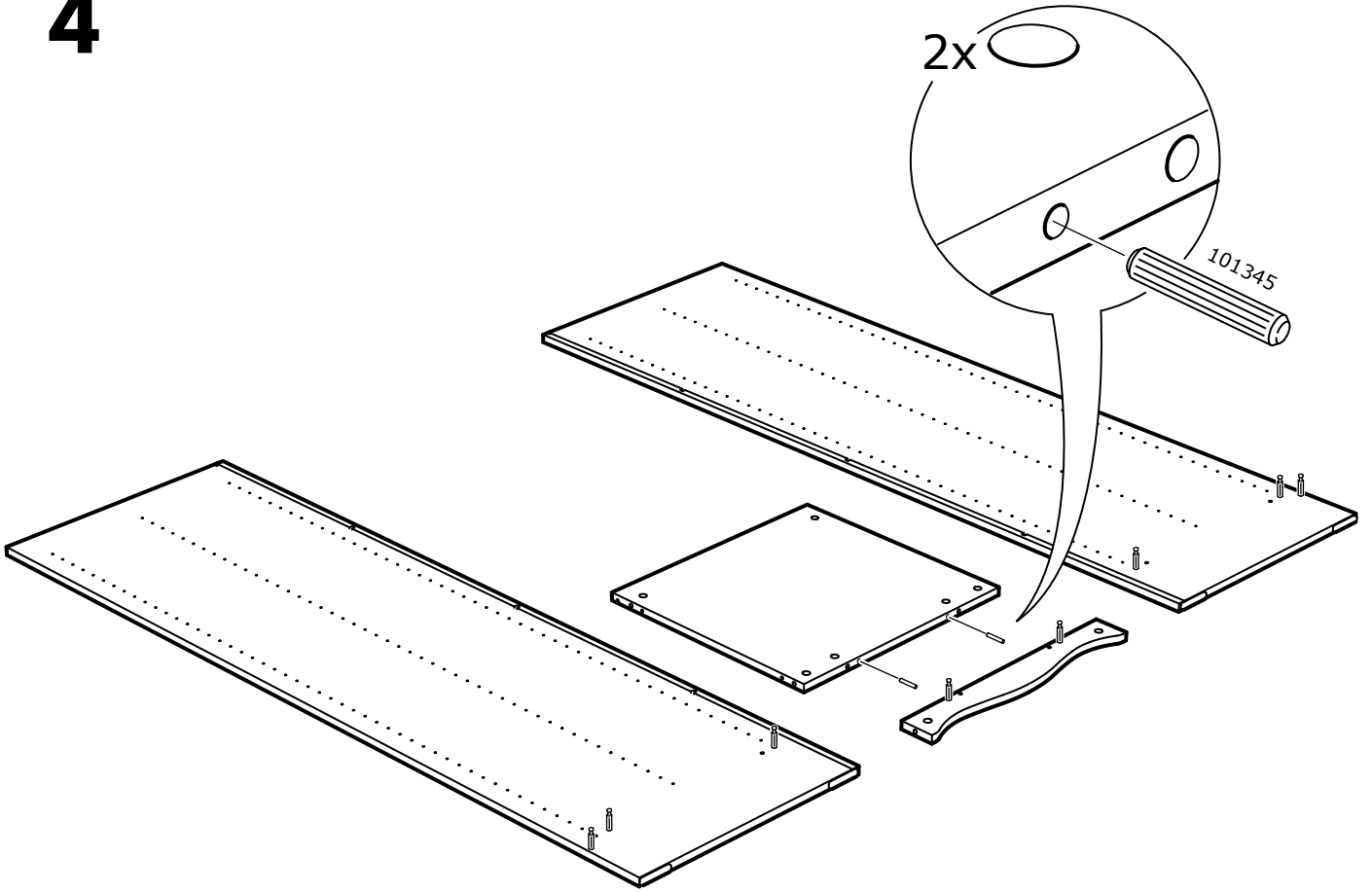

5

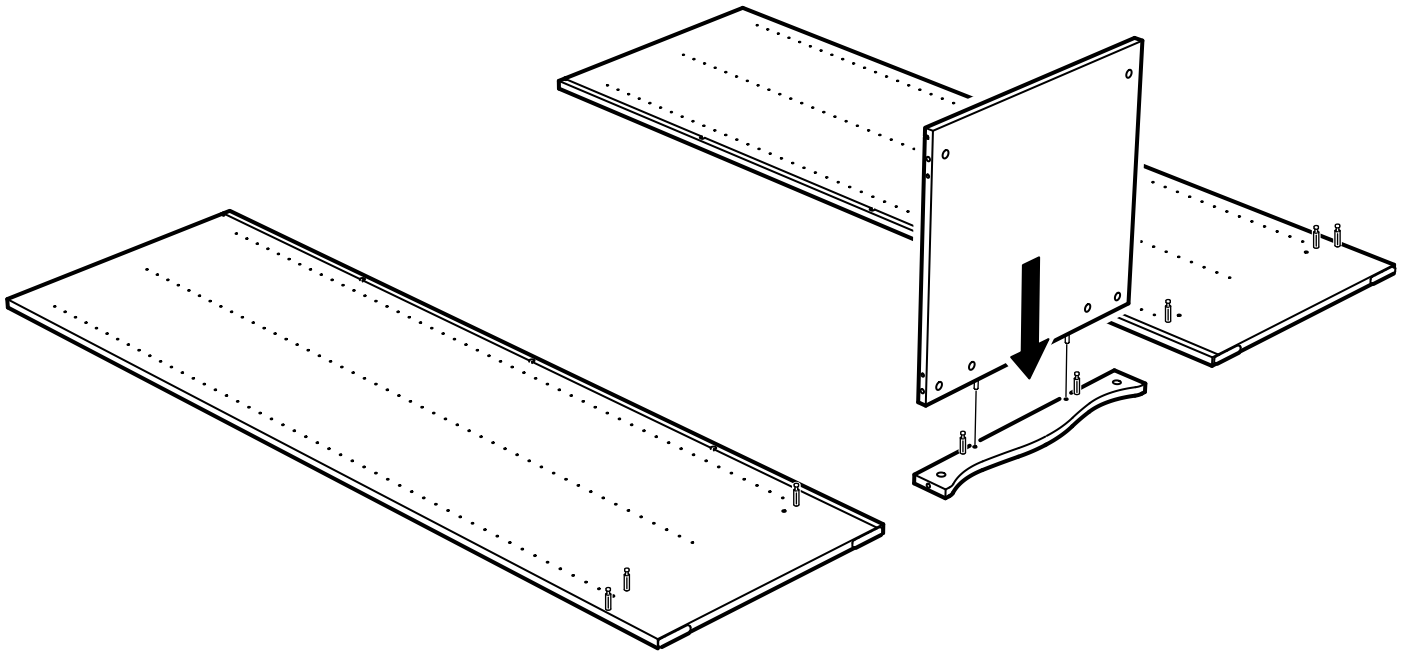

6

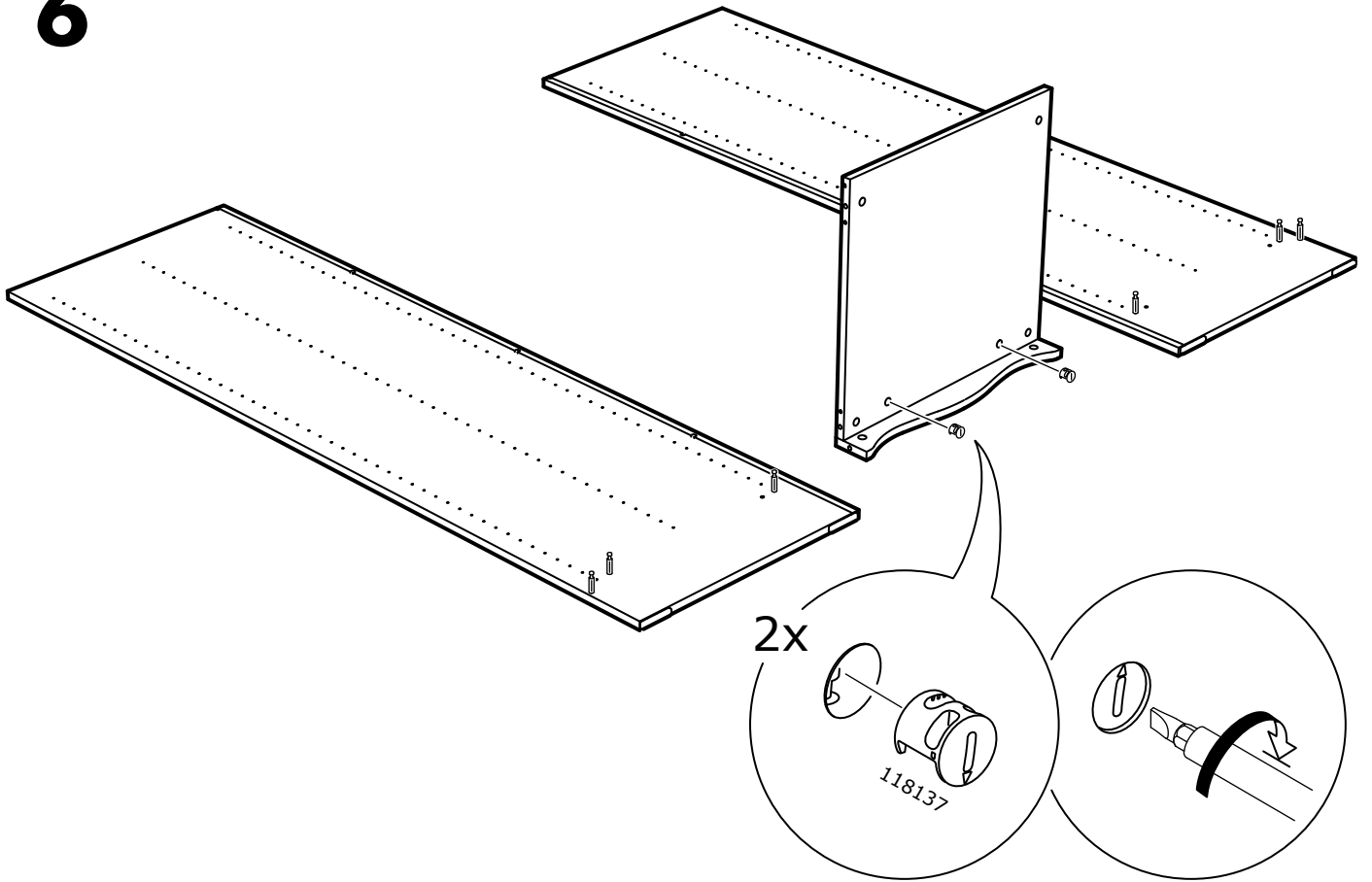

7

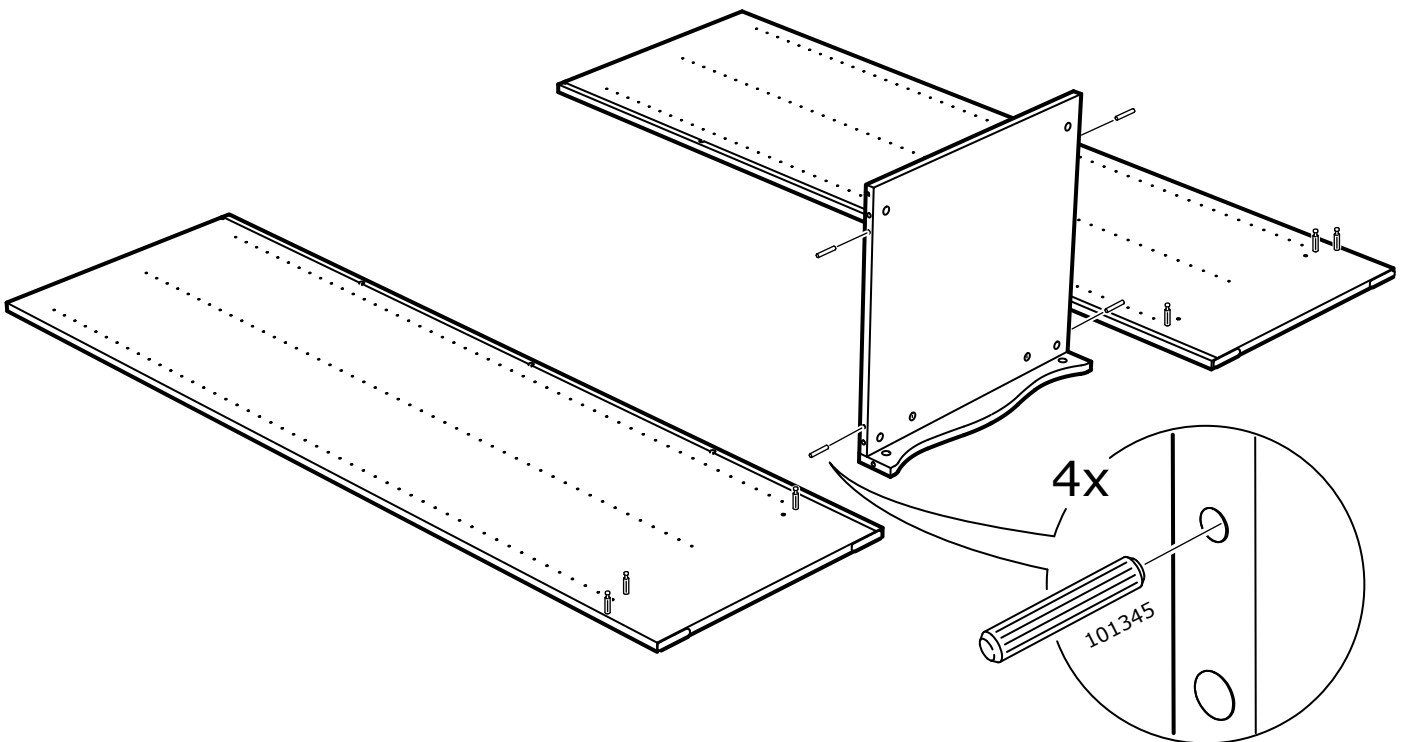

8

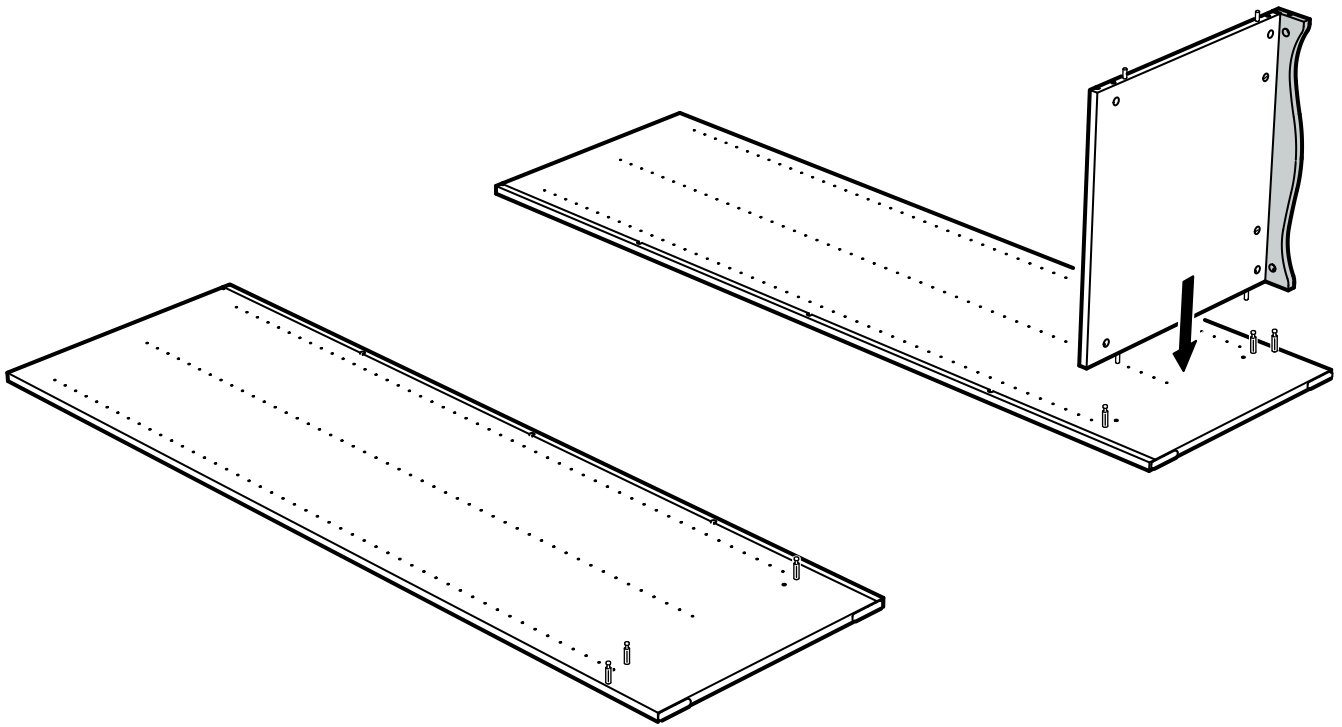

9

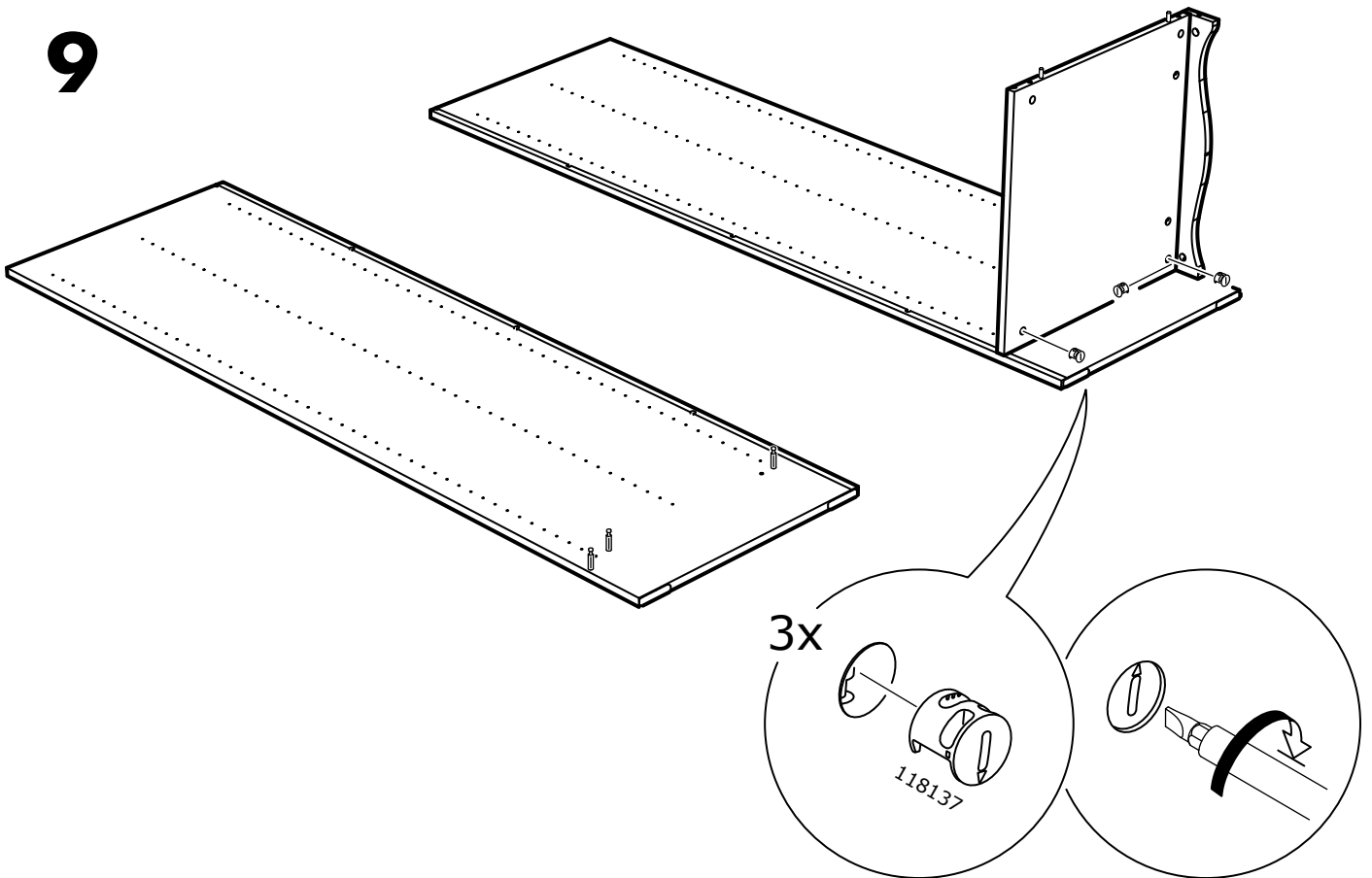

10

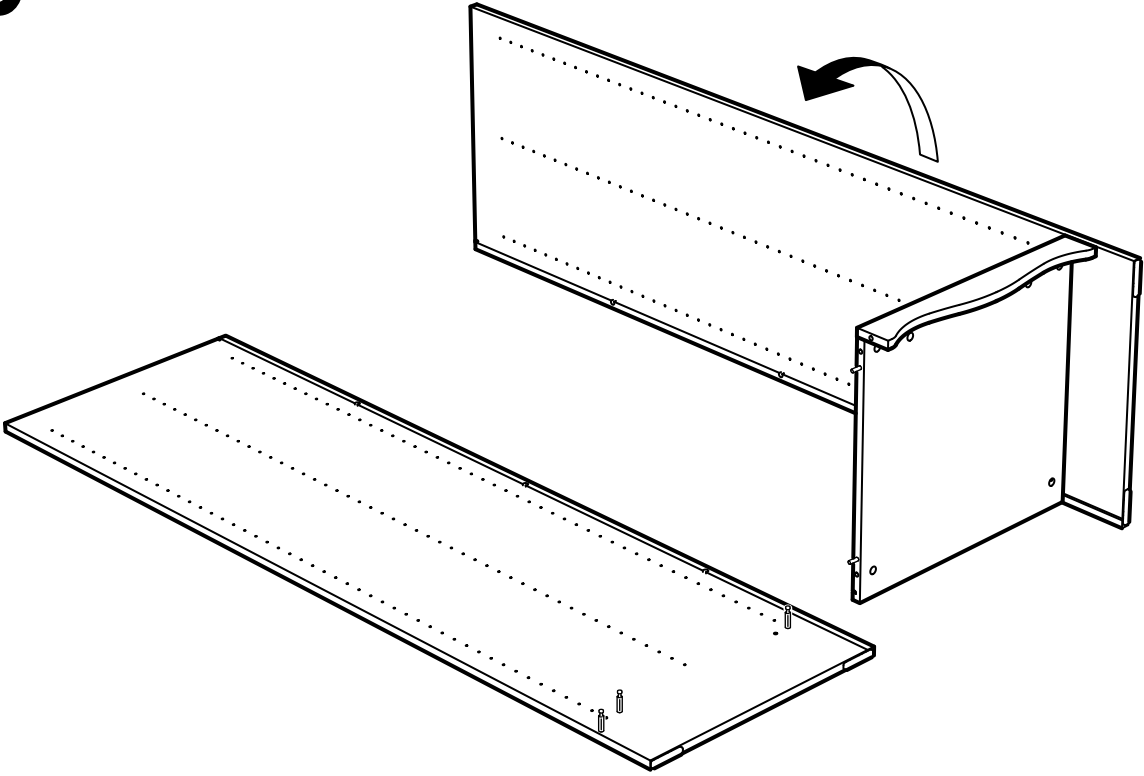

11

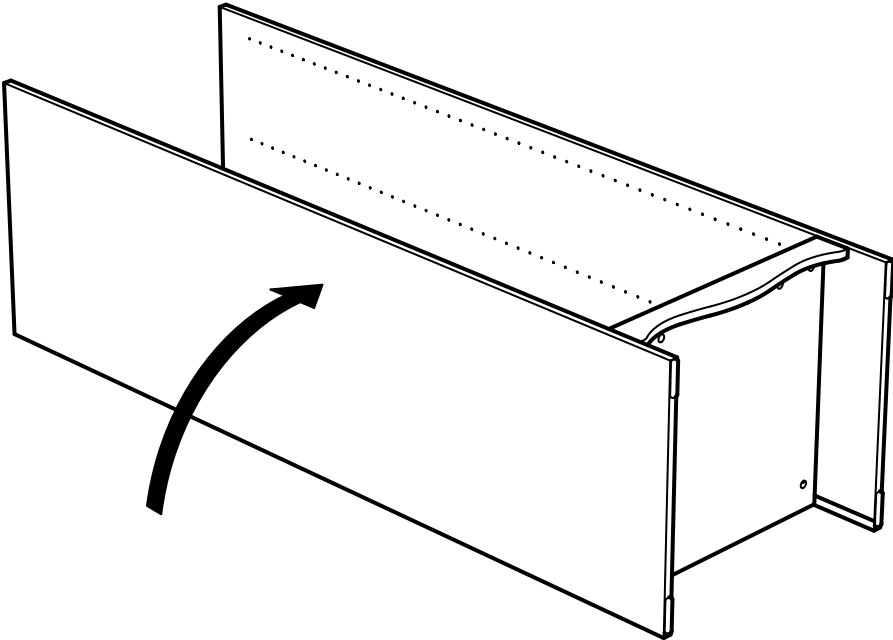

12

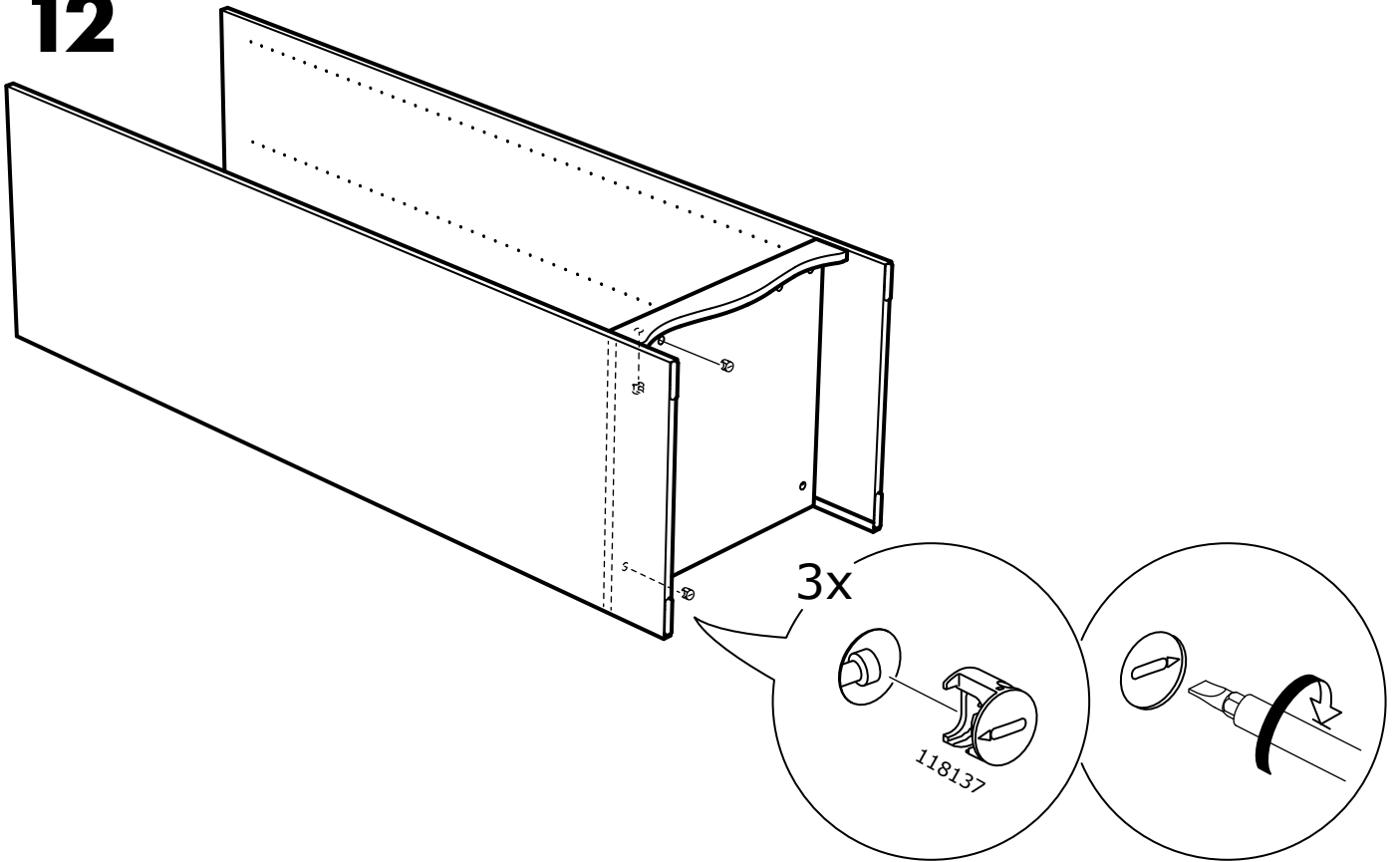

13

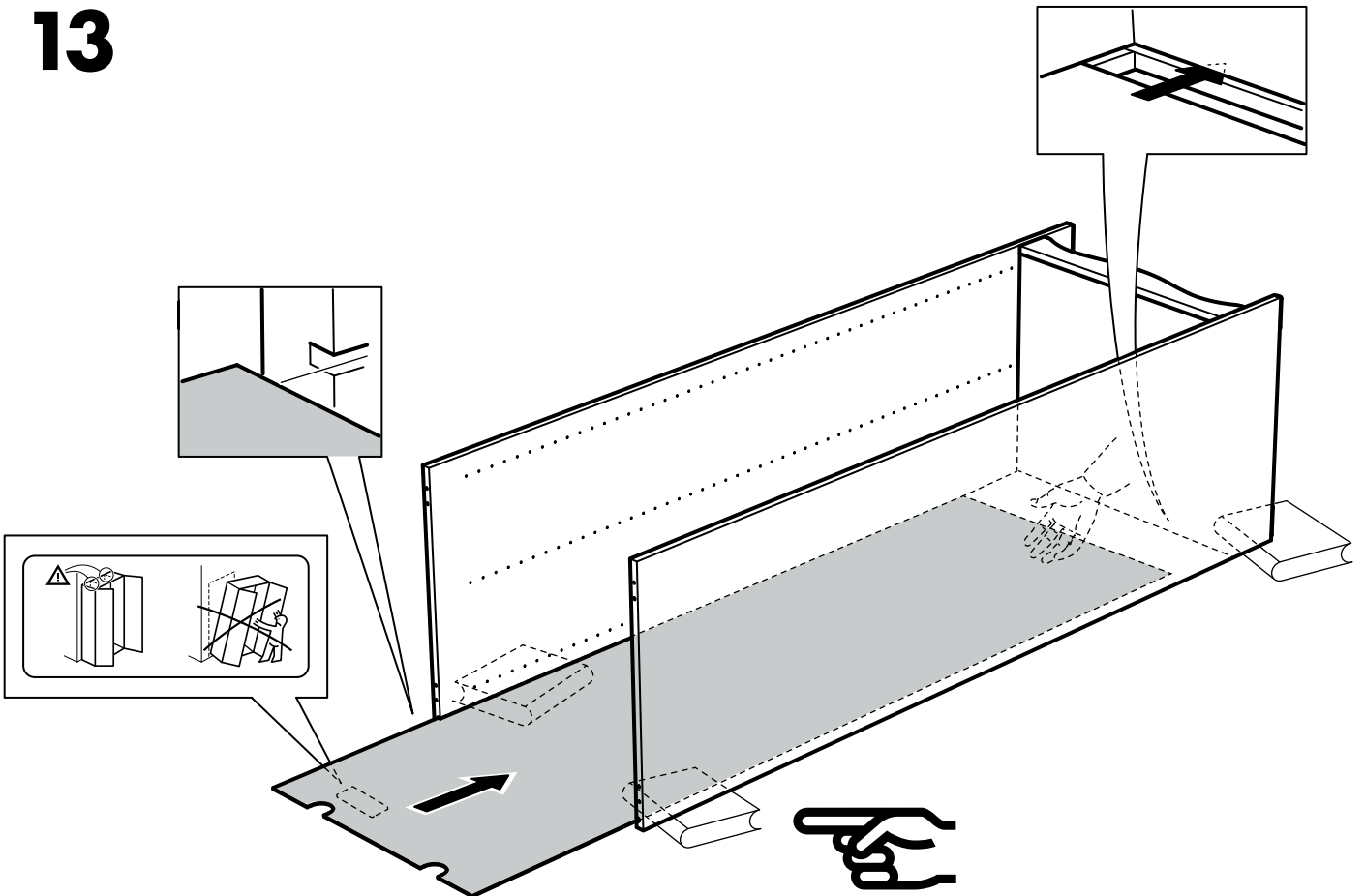

14

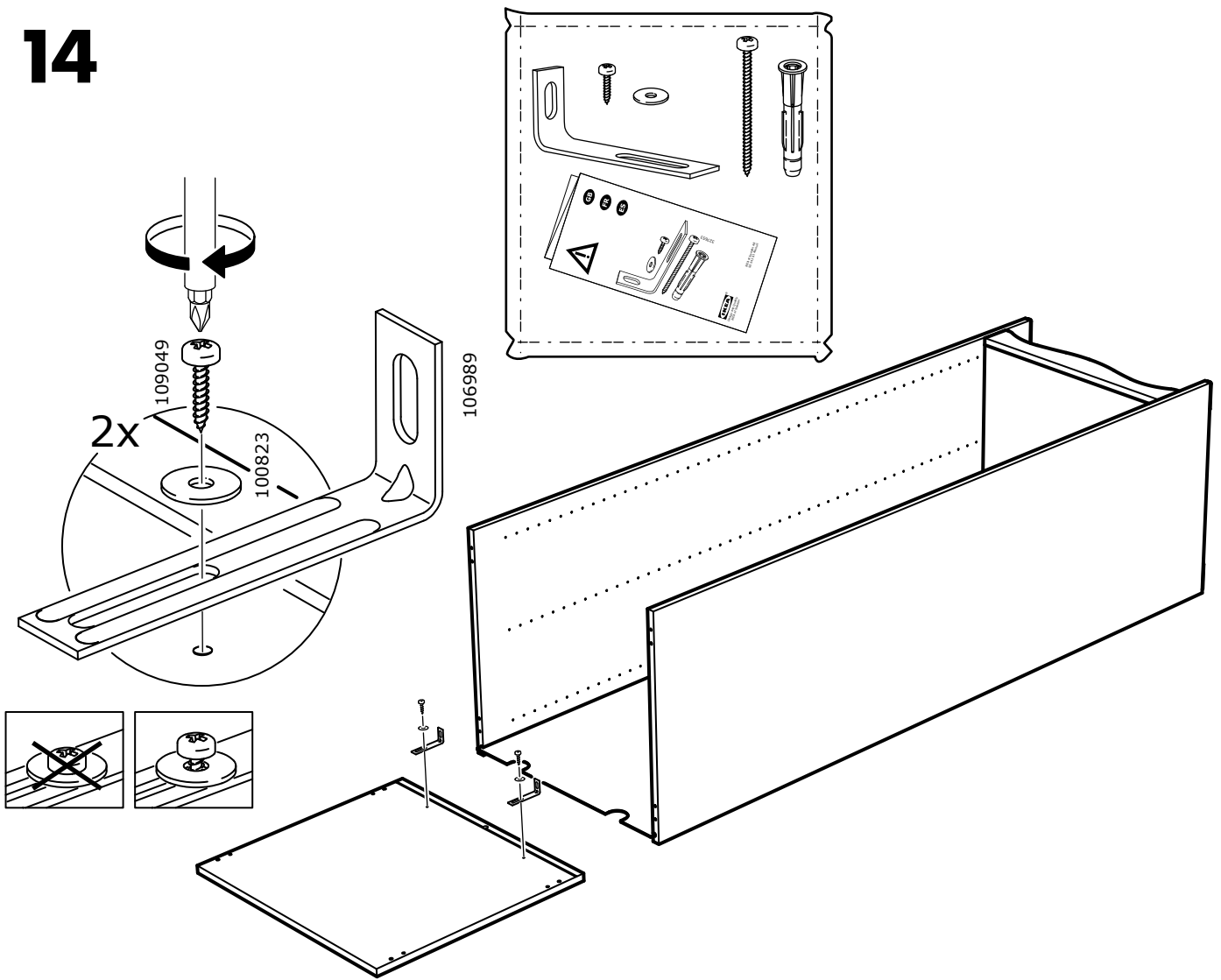

15

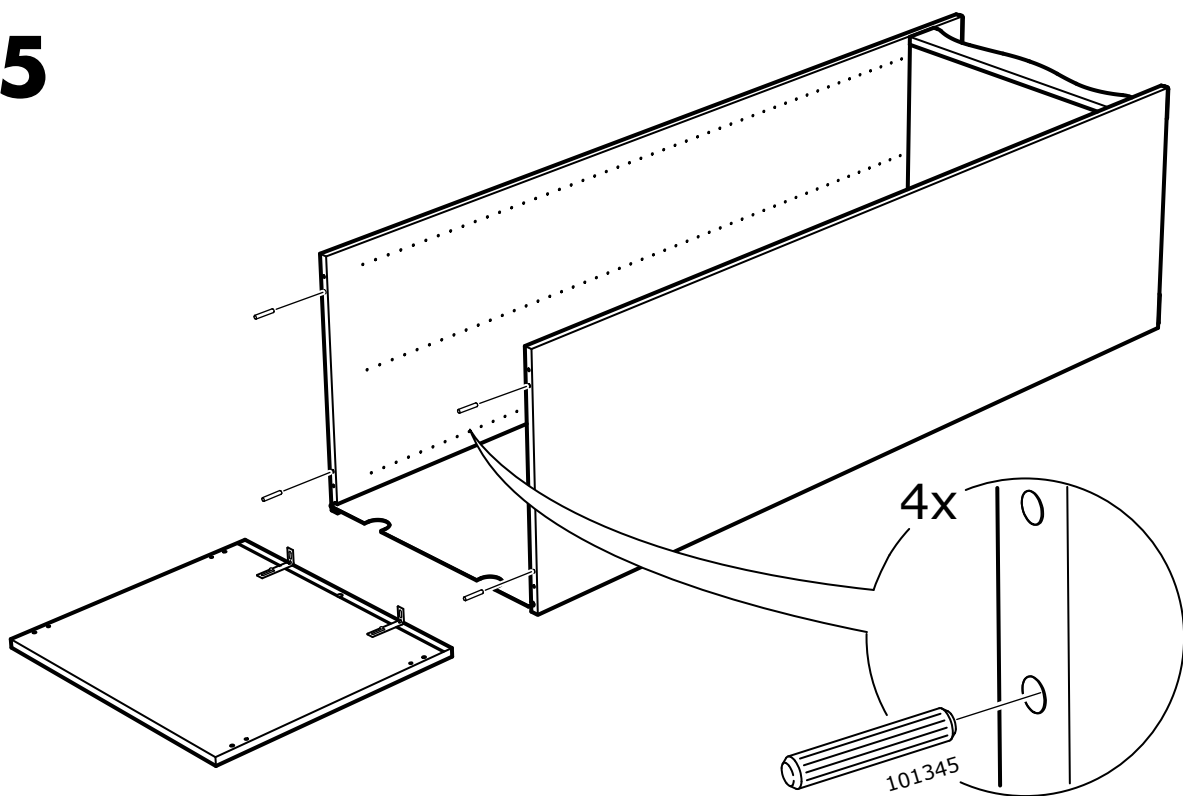

16

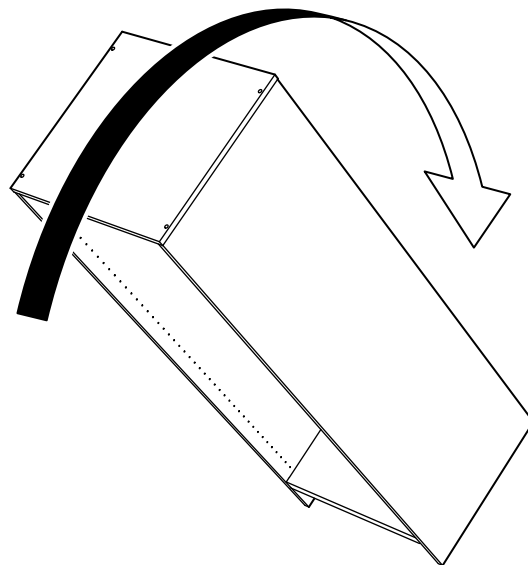
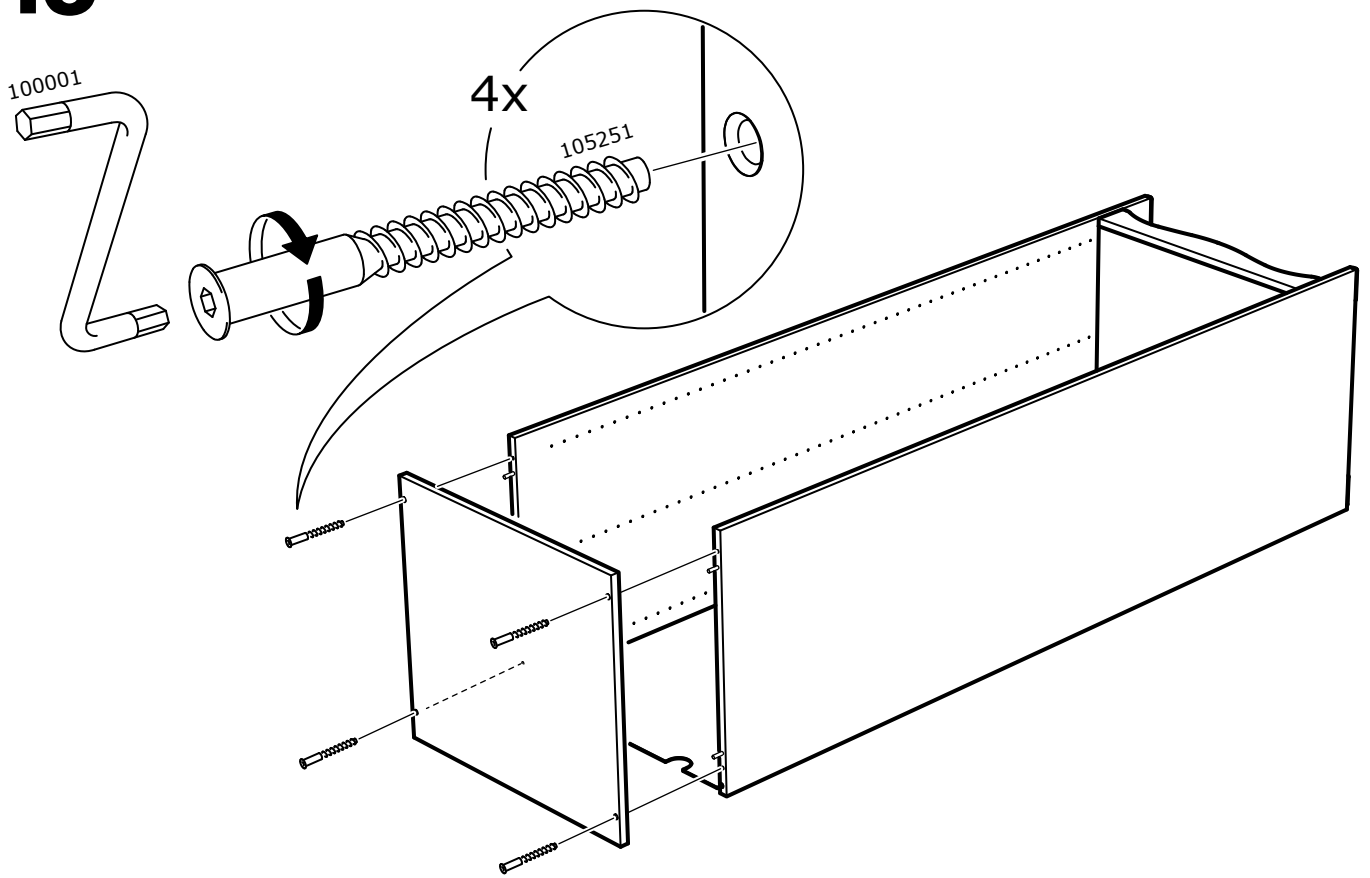

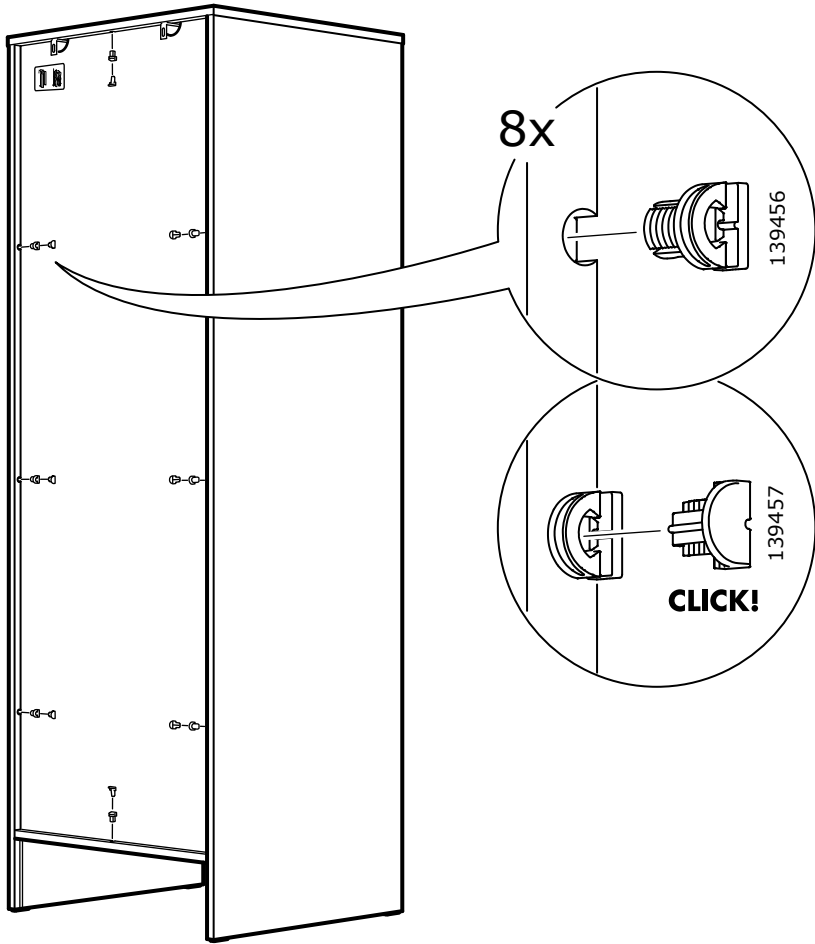

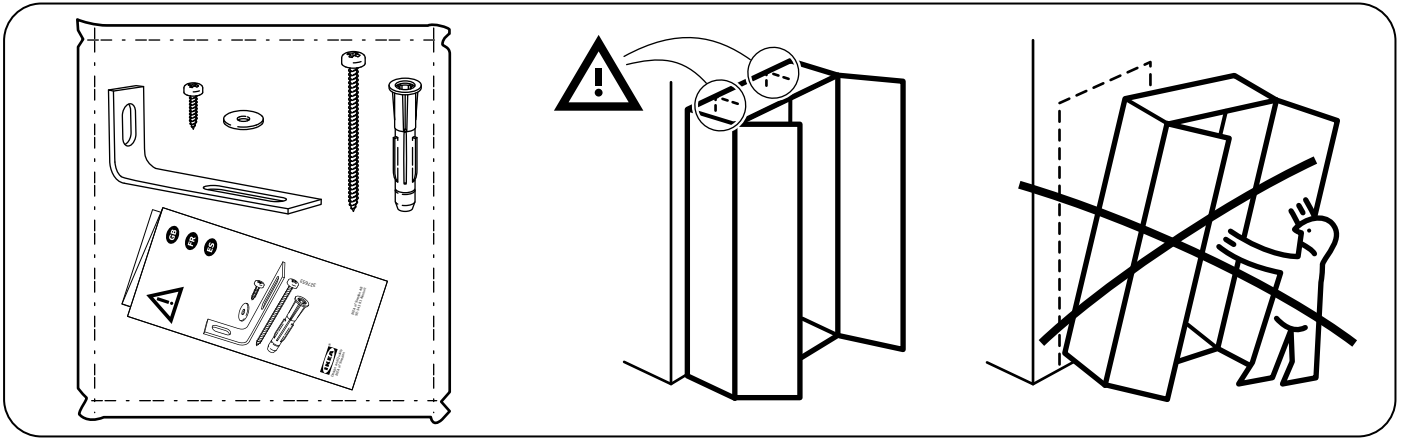

18

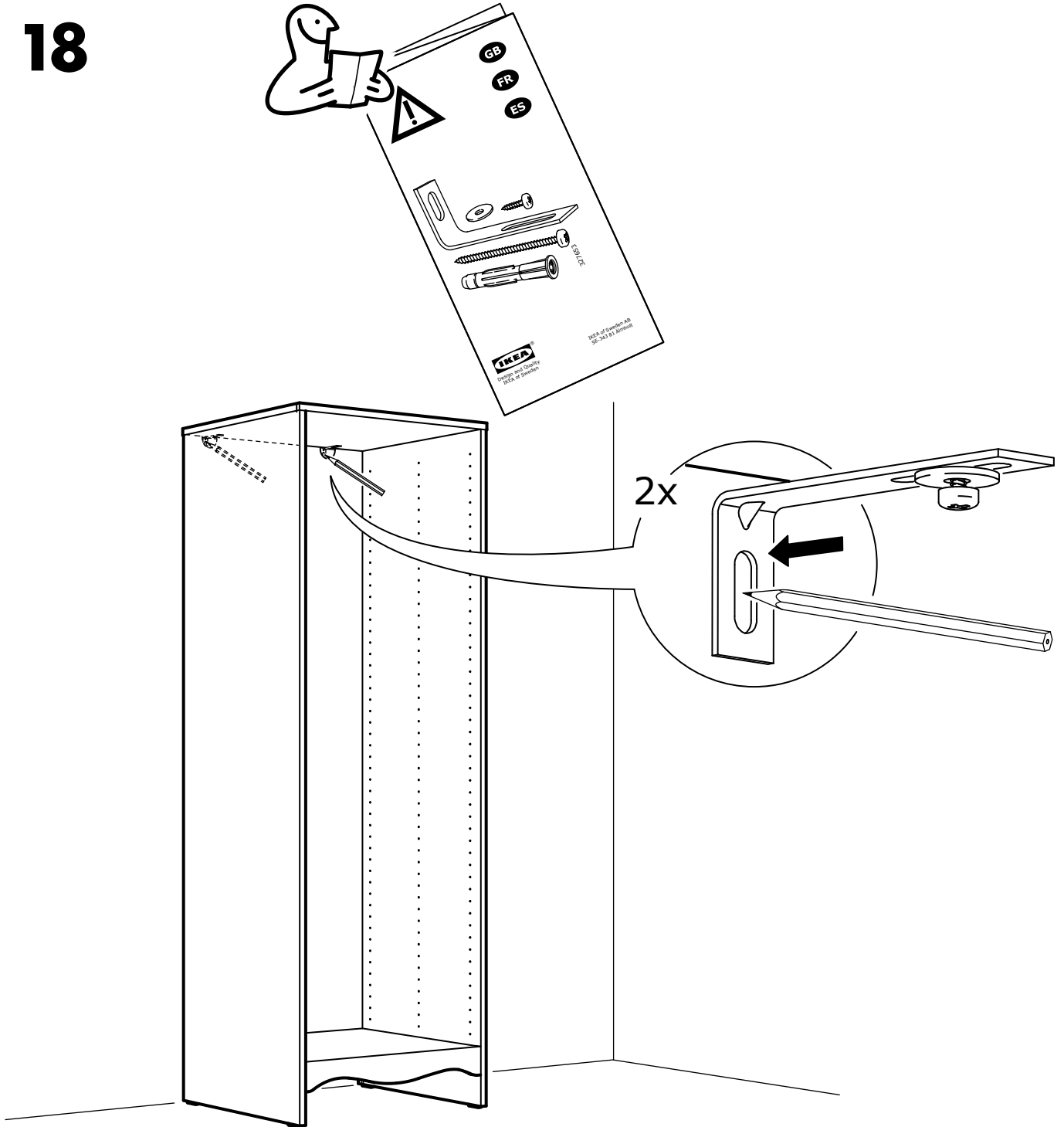

19

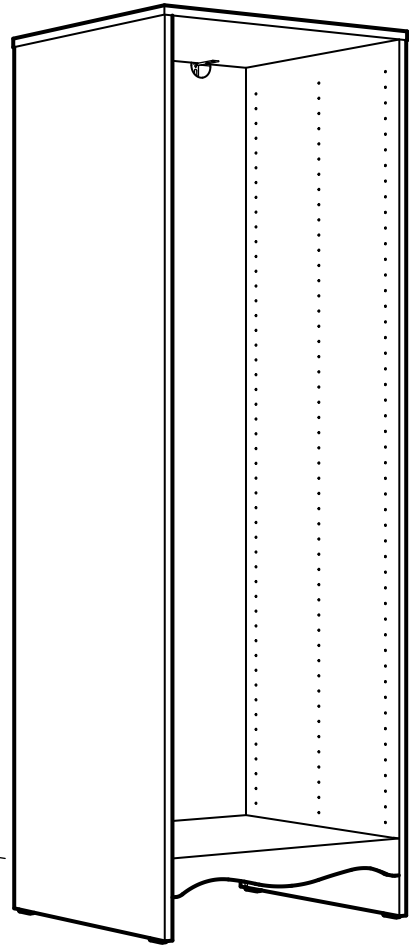
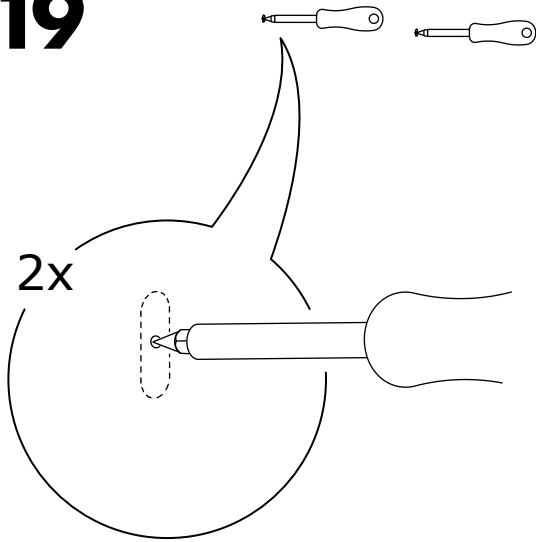

20

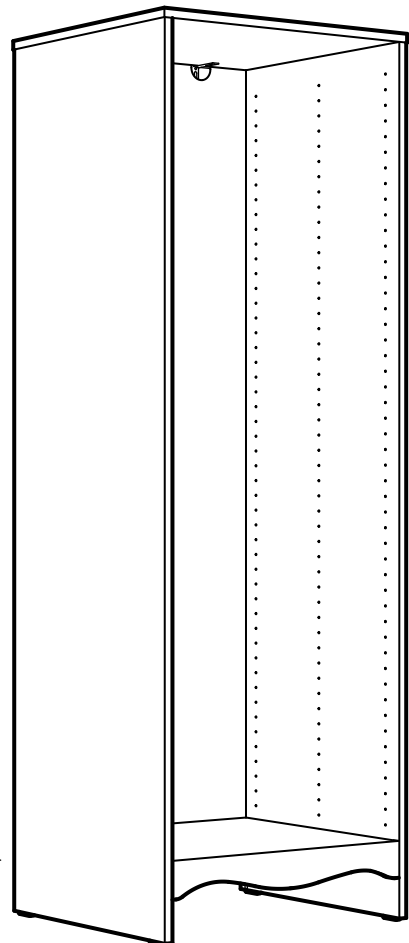
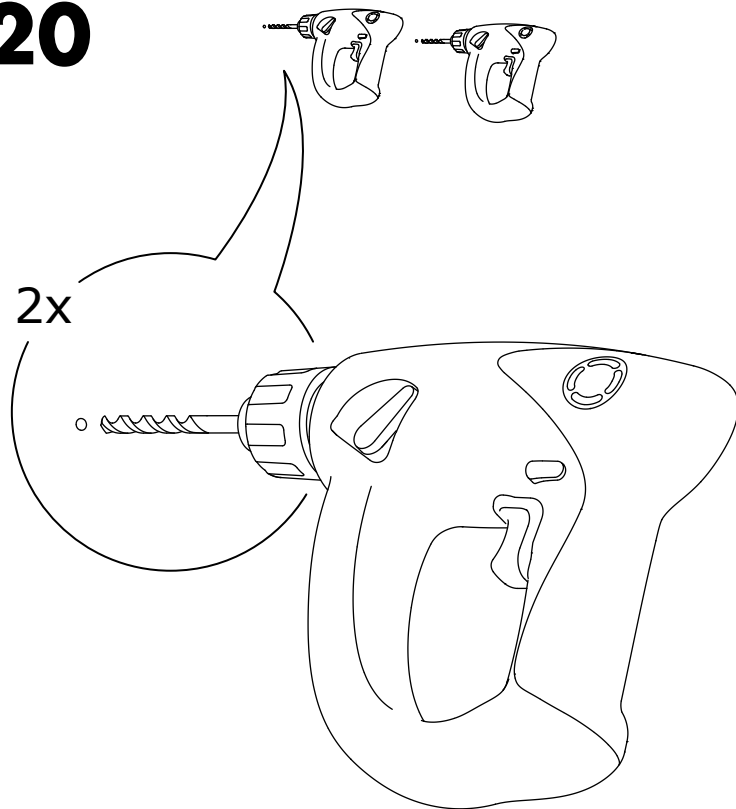

21

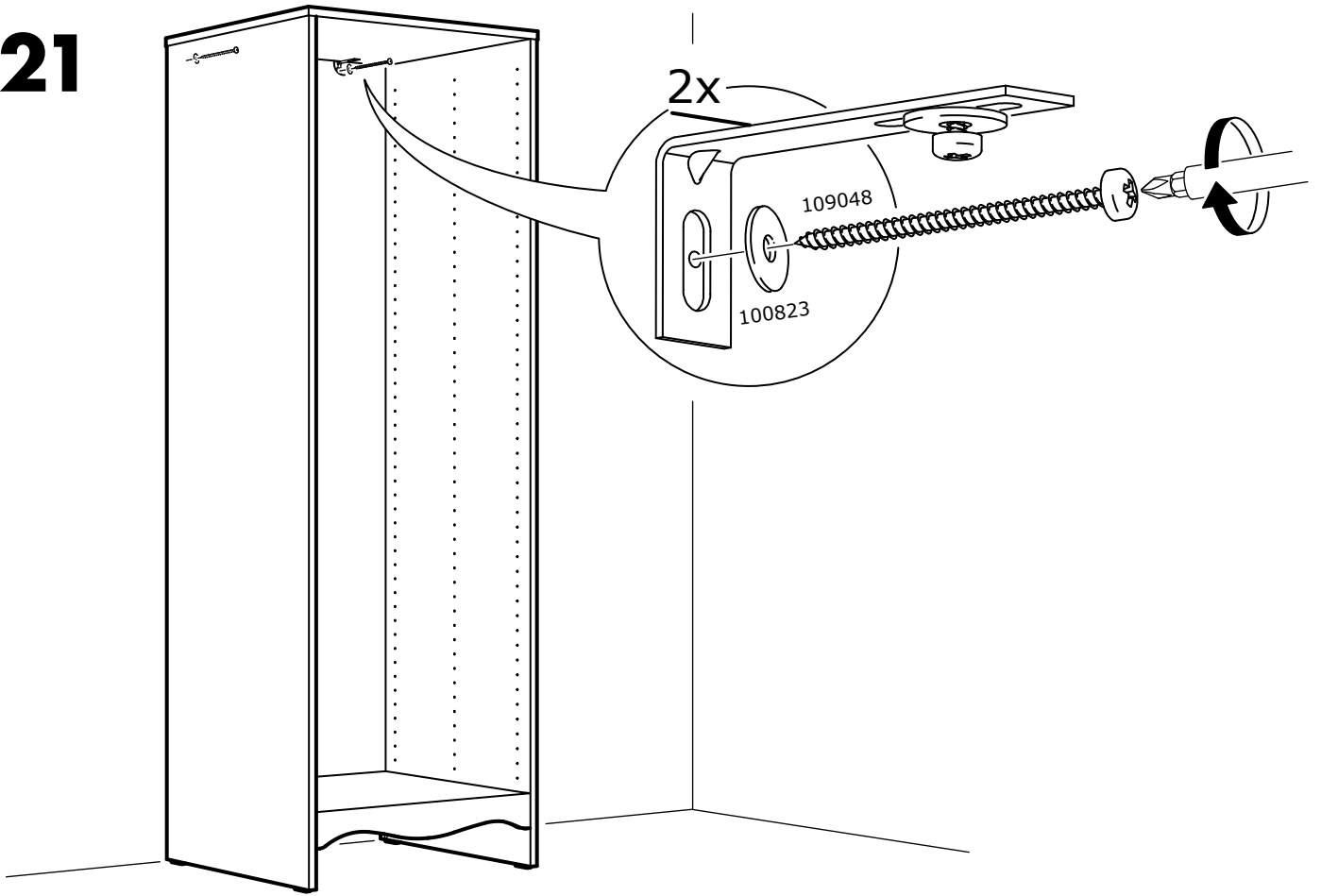

22

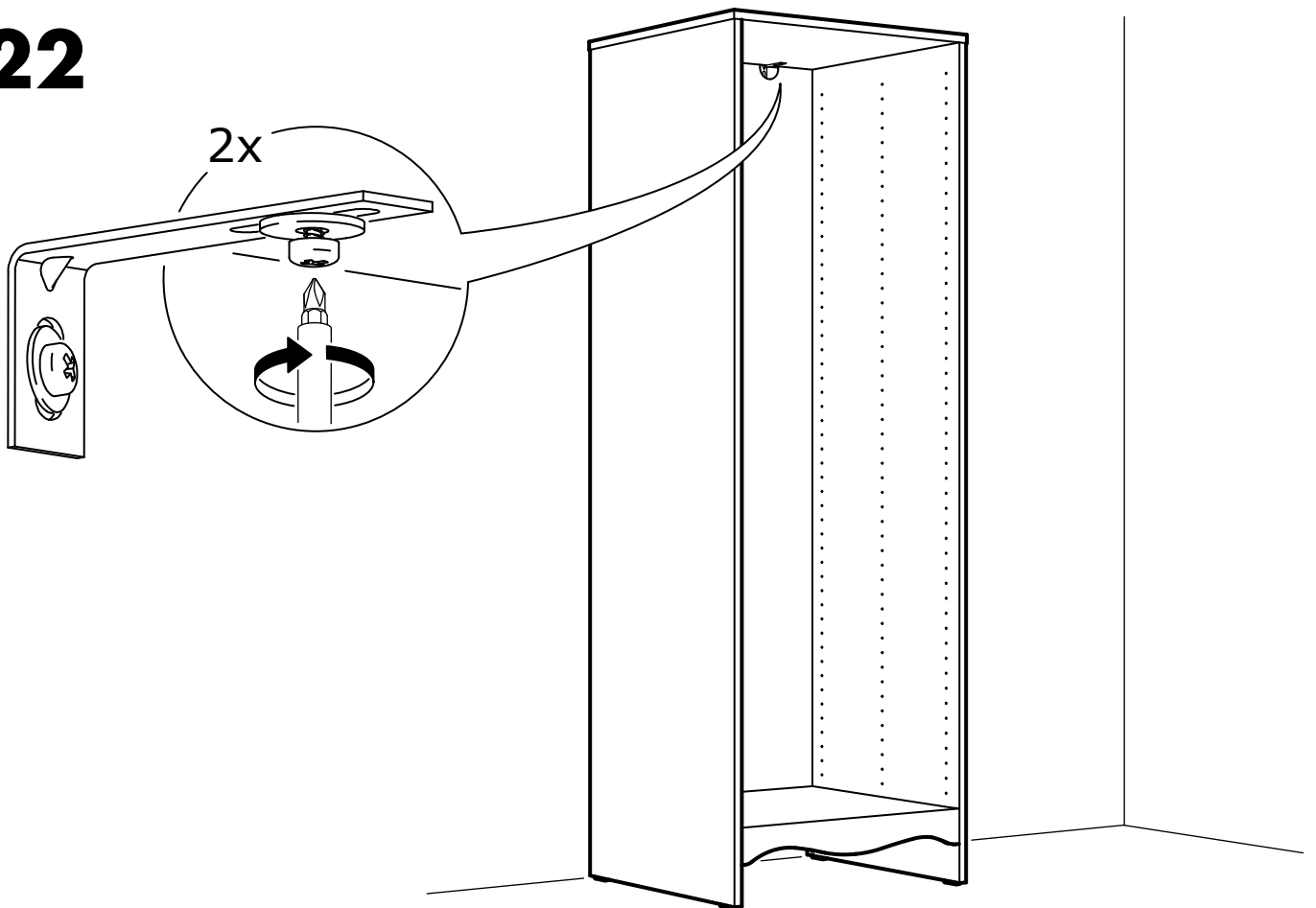

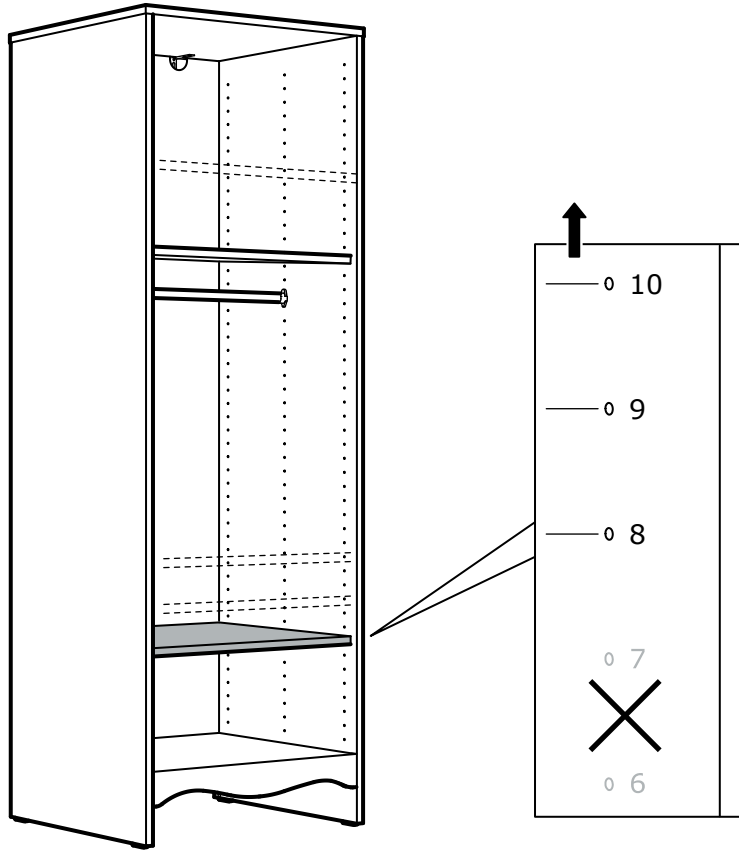

23

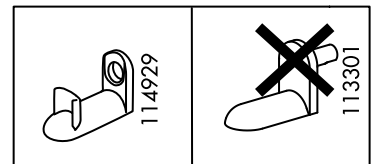
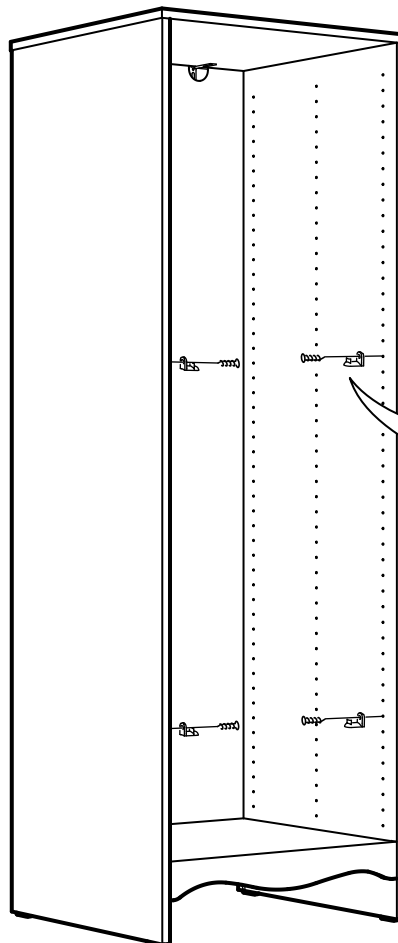
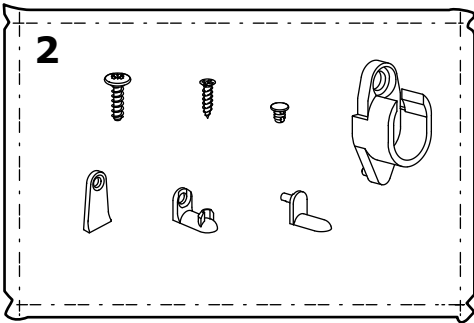

4x

116637 114929

24

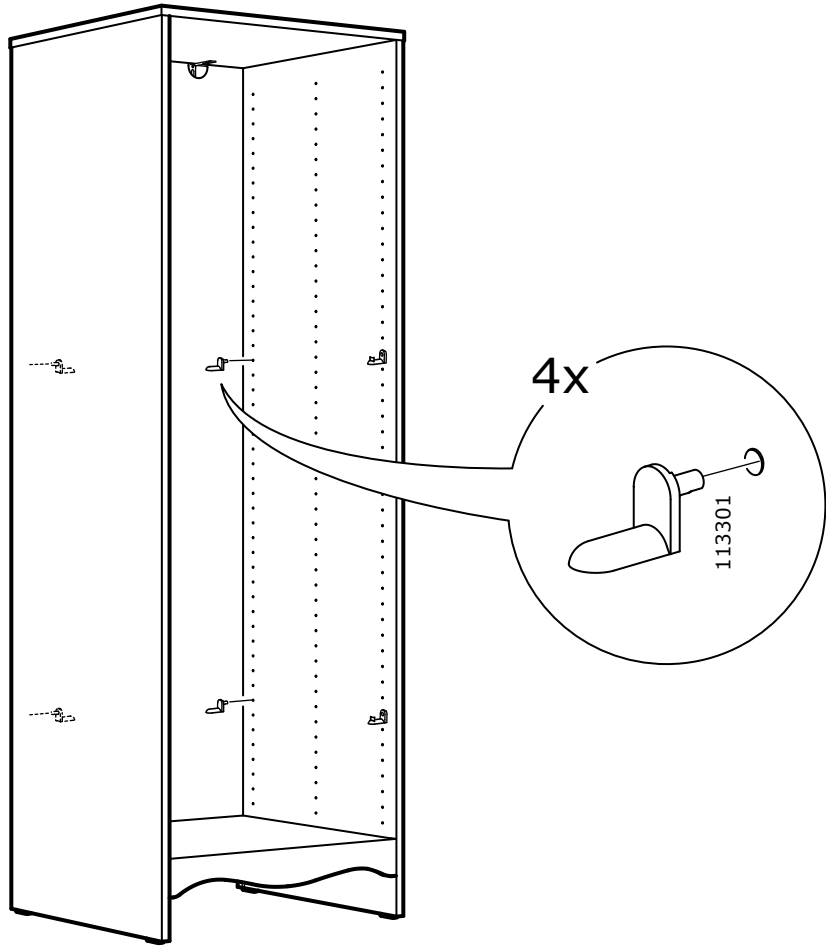

25

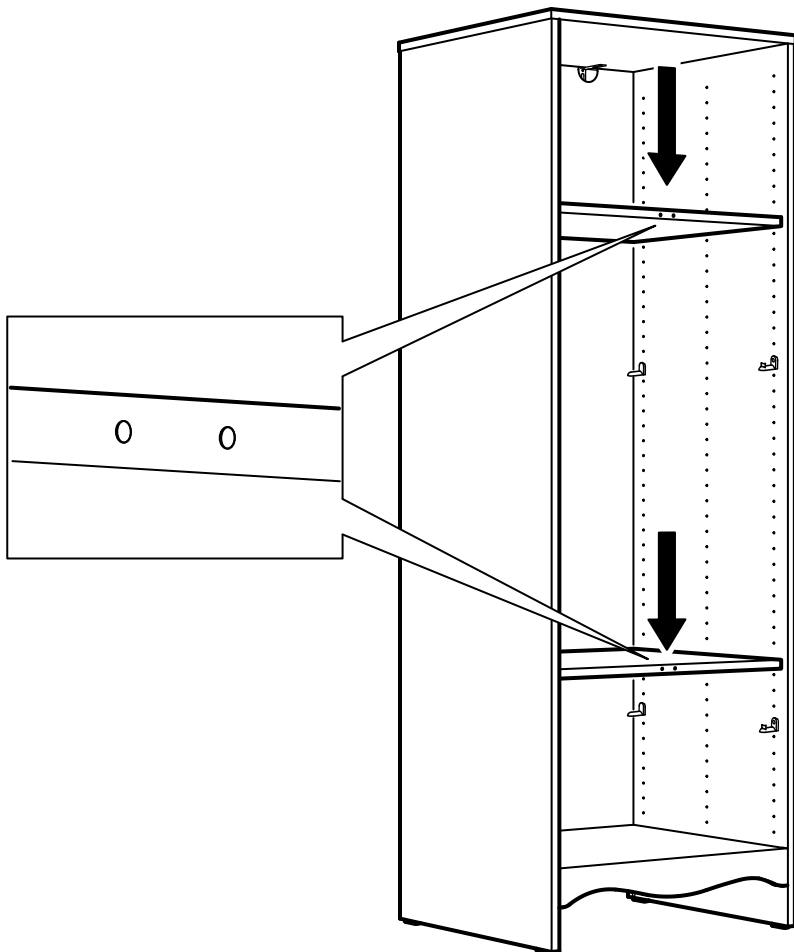

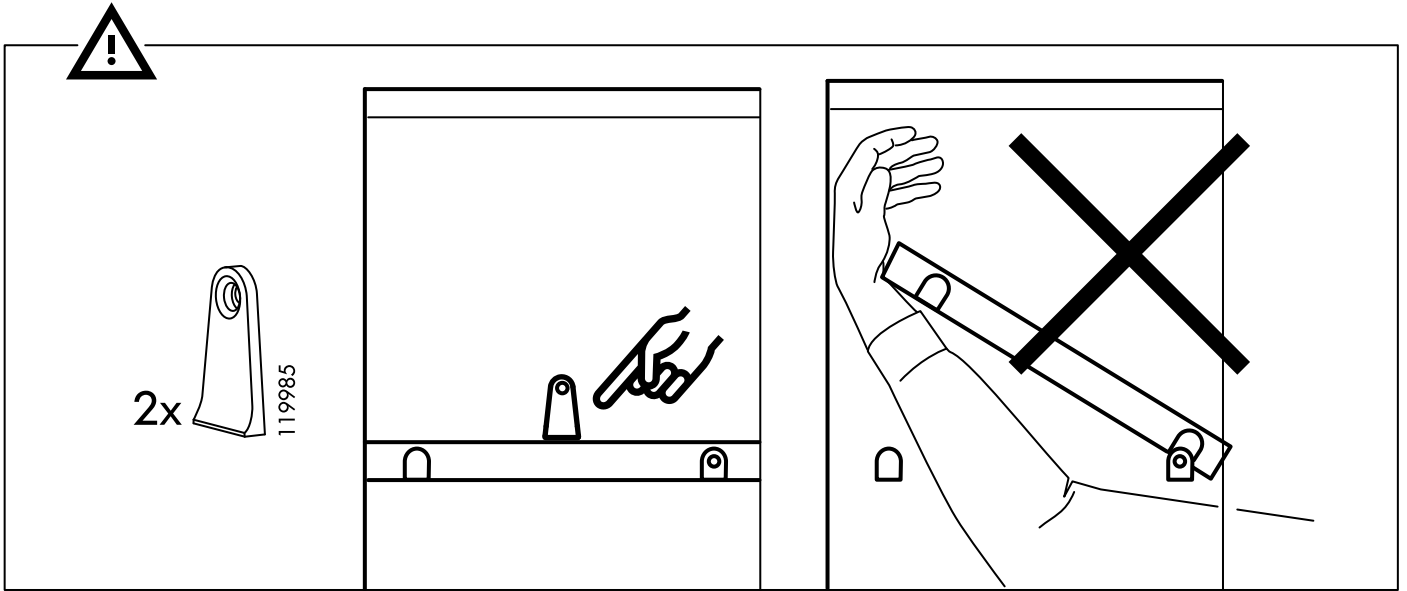

26

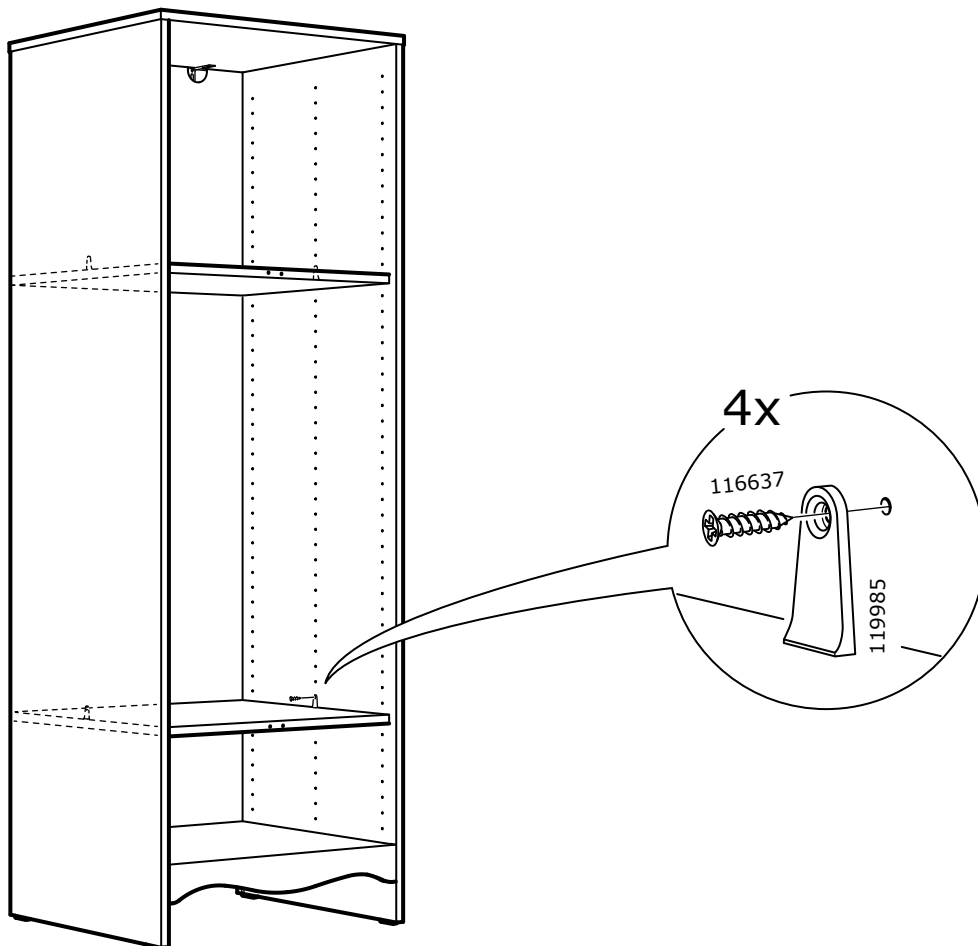

27

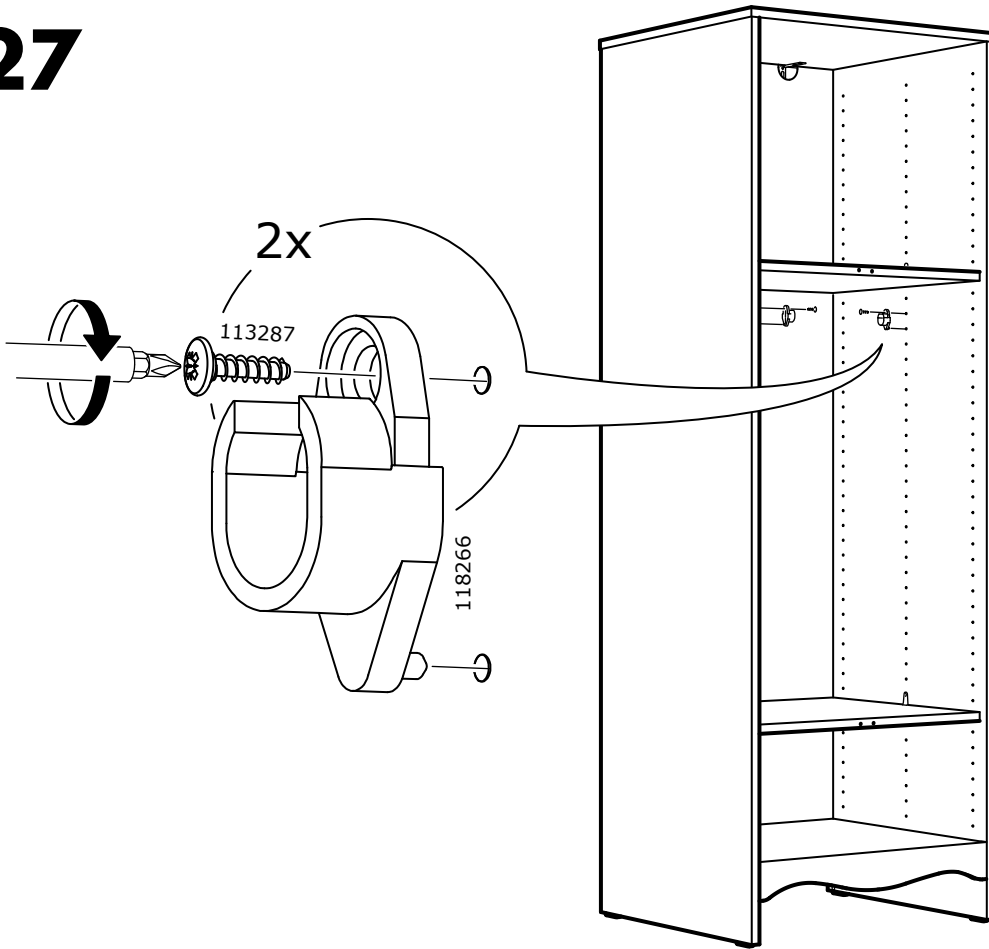

28

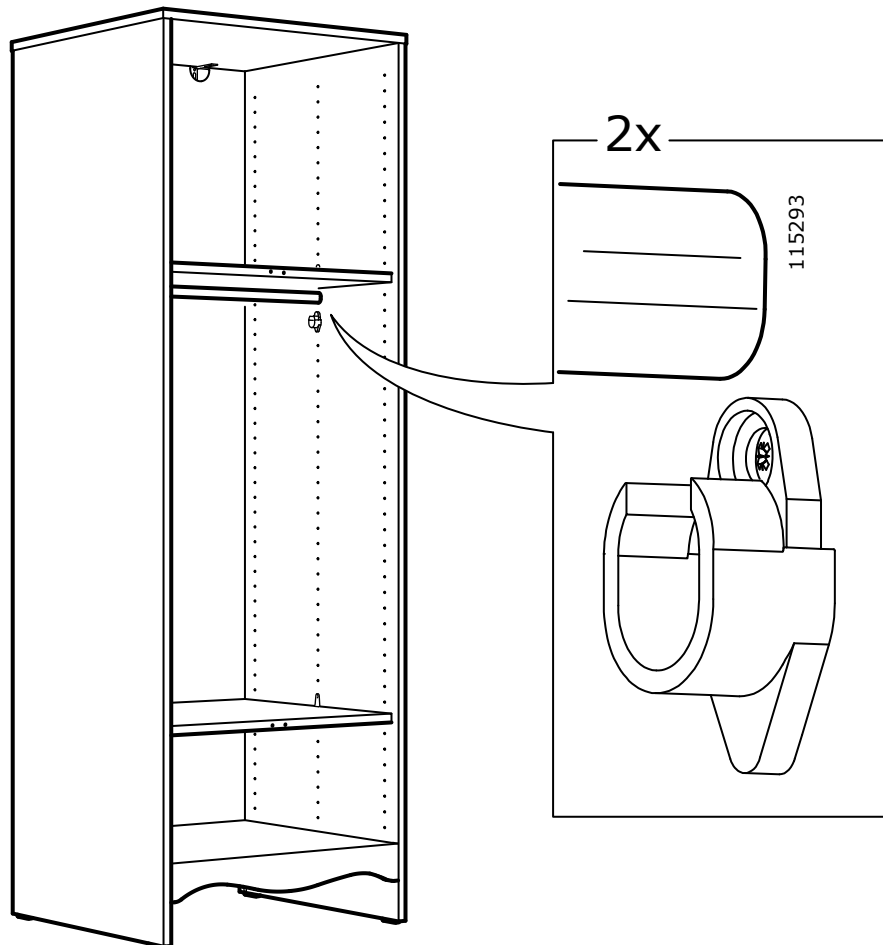

29

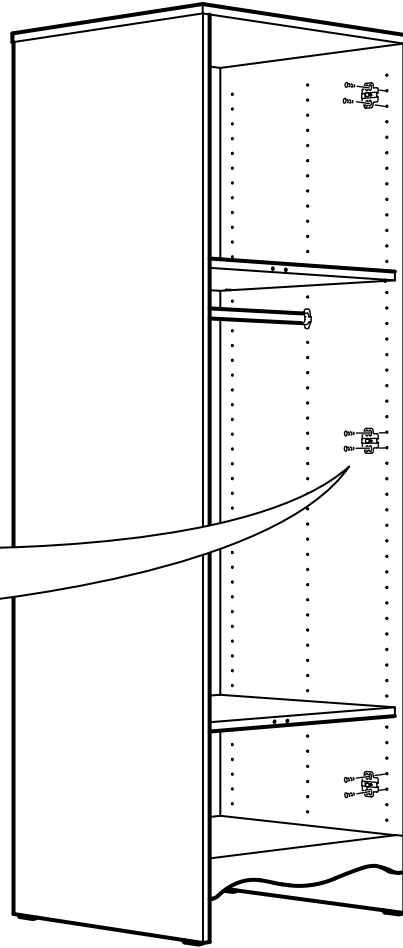
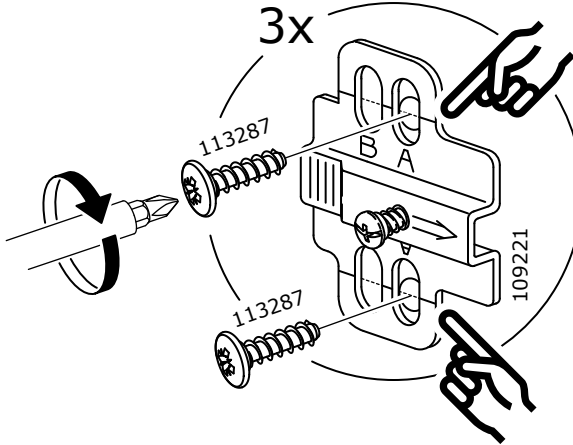
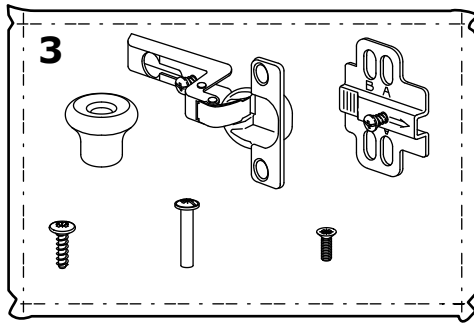

30

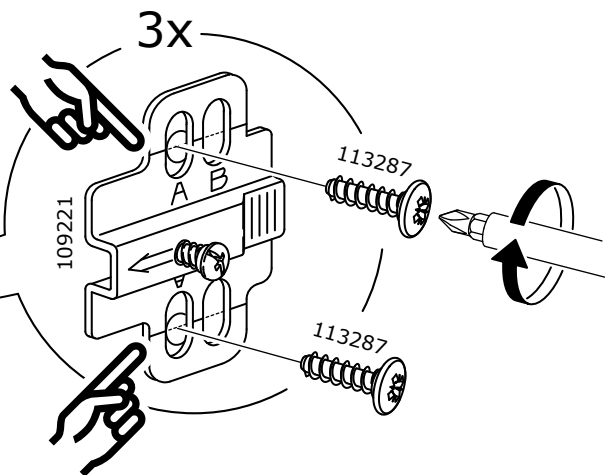
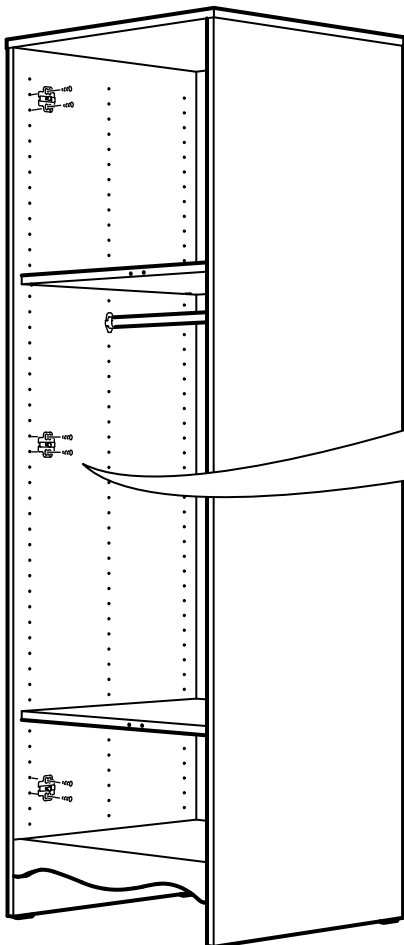

31

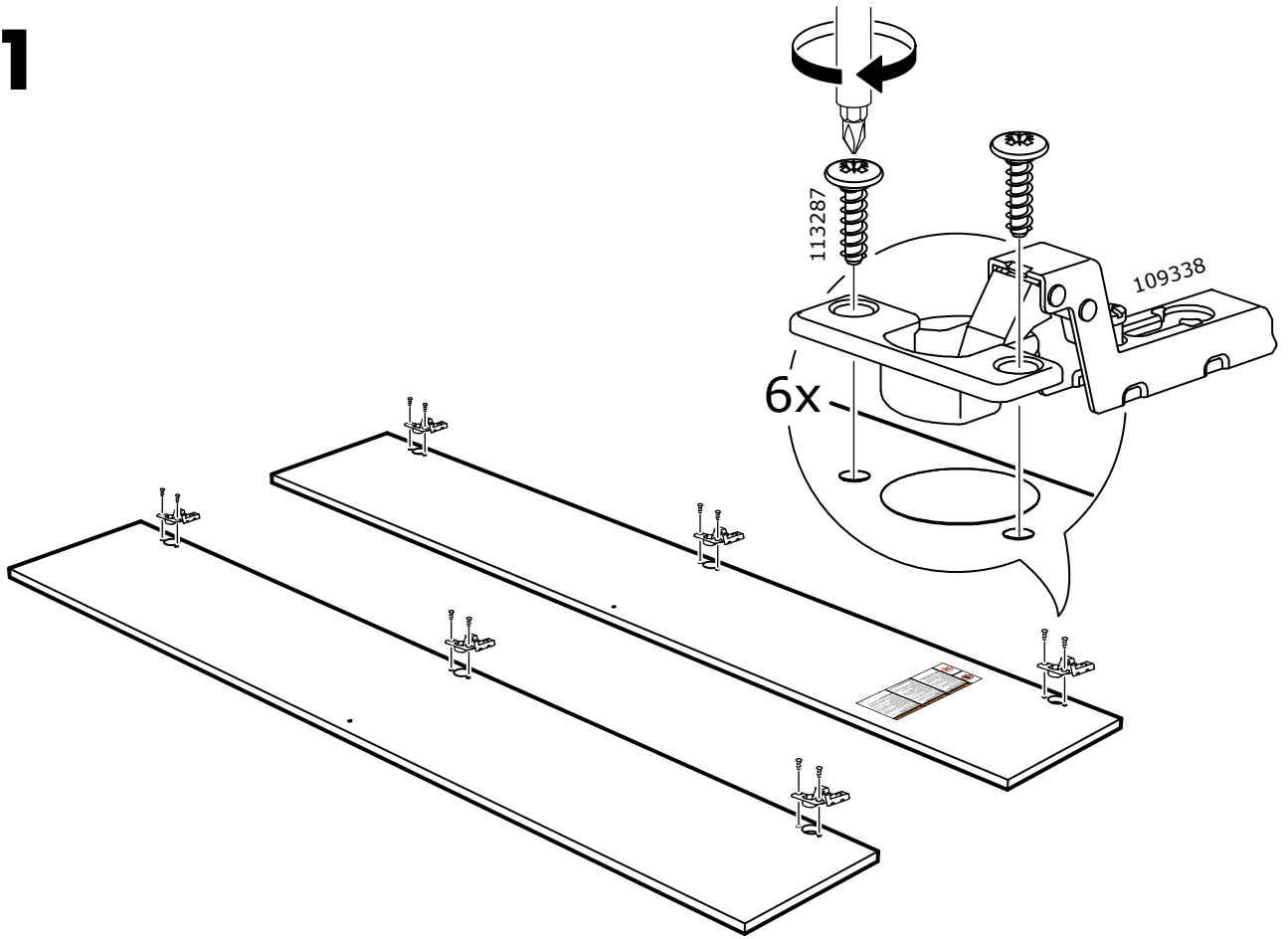

32

