

# SÖDERSVIK

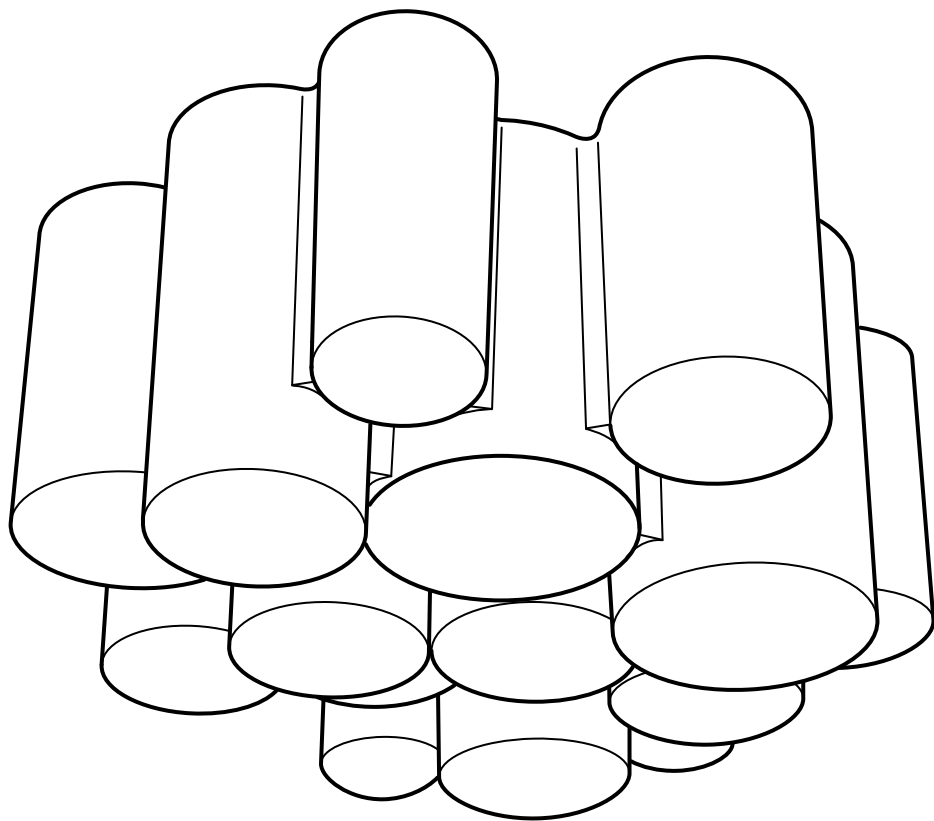

Design and Quality  
IKEA of Sweden



**ENGLISH**  
INSTALLATION INSTRUCTIONS

## CAUTION:

Before starting, turn off power at main circuit panel.

**ENGLISH**

## CAUTION!

The light source of this product is non-changeable light diodes (LED). Do not disassemble the product, as the light diodes can cause damage to the eyes.

Do not immerse in water

**ENGLISH**

This device complies with part 15 of the FCC Rules. Operation is subjected to the following two conditions:

1. This device may not cause harmful interference, and
2. this device must accept any interference received, including interference that may cause undesired operation.

## WARNING

Changes or modifications not expressly approved by the party responsible for compliance could void the user's authority to operate the equipment.

---

**FRANÇAIS**  
INSTRUCTIONS D'INSTALLATION

## ATTENTION:

coupez l'alimentation avant de procéder à l'installation.

**FRANÇAIS**

## ATTENTION!

La source lumineuse de ce produit se compose de diodes électroluminescentes non remplaçables (LED). Ne pas démonter le produit car les diodes électroluminescentes peuvent abîmer les yeux.  
Ne pas plonger dans l'eau.

**FRANÇAIS**

Cet appareil est conforme à la partie 15 des règles de la FCC. Son fonctionnement est soumis aux deux conditions suivantes :

1. Cet appareil ne doit pas provoquer de brouillage préjudiciable et
2. il doit accepter tout brouillage reçu, y compris le brouillage pouvant entraîner un mauvais fonctionnement.

## ATTENTION:

Tout changement apporté à cet appareil non expressément approuvé par la partie responsable de la conformité est susceptible d'annuler le droit de l'utilisateur à se servir de cet équipement.



**ESPAÑOL**  
INSTRUCCIONES DE MONTAJE

## **ADVERTENCIA:**

Antes de comenzar el montaje, cortar la luz en el cuadro general.

**ESPAÑOL**

## **¡ADVERTENCIA!**

La fuente luminosa de este producto es un diodo de emisión de luz (LED) que no se puede sustituir.

No desmontes el producto, porque los diodos pueden dañar la vista.

No lo sumerjas en agua.

**ESPAÑOL**

Este aparato cumple la parte 15 de las normas FCC. Su funcionamiento está sujeto a las dos condiciones siguientes:

1. Este aparato no debe provocar interferencias perjudiciales.
2. Debe aceptar cualquier interferencia que reciba, incluidas las interferencias que puedan suponer un mal funcionamiento.

## **ATENCIÓN:**

Cualquier cambio o modificación que se realice sin ser aprobado expresamente por la parte responsable de la conformidad, es susceptible de anular el derecho del usuario a utilizar este equipo.

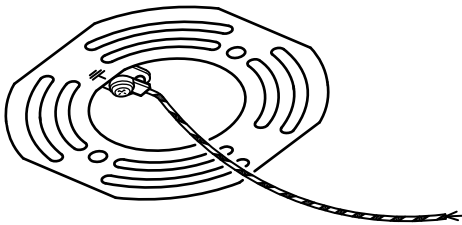
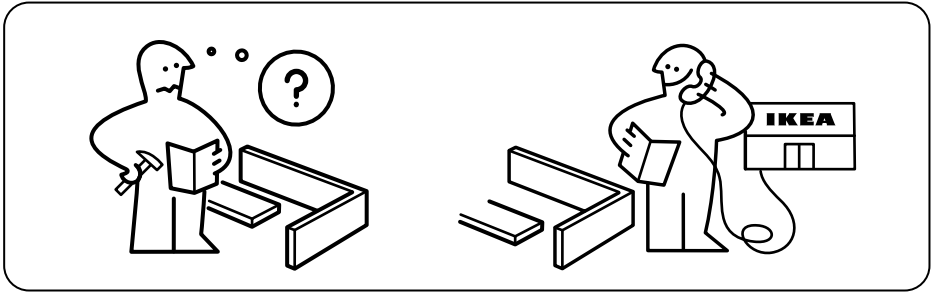
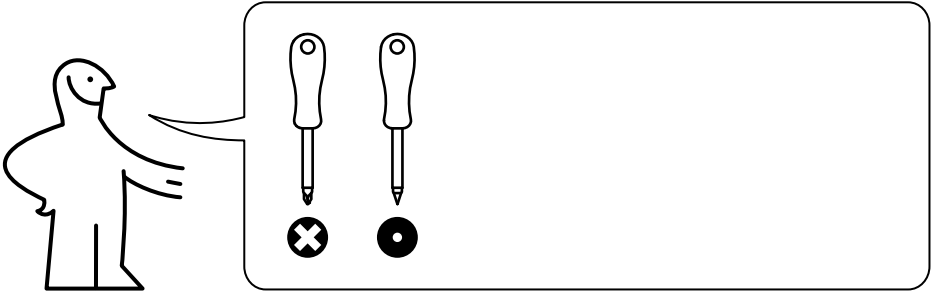

1x

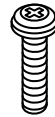

2x

**1**

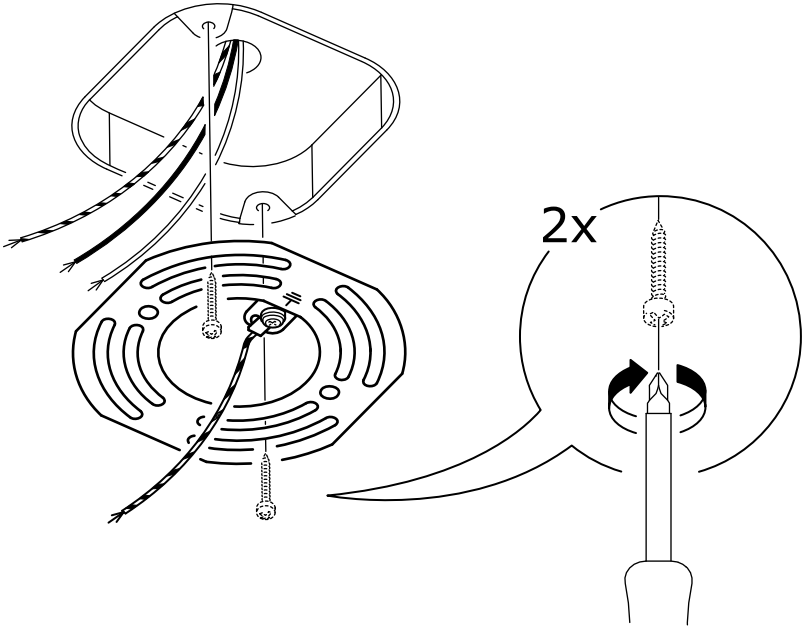

**2**

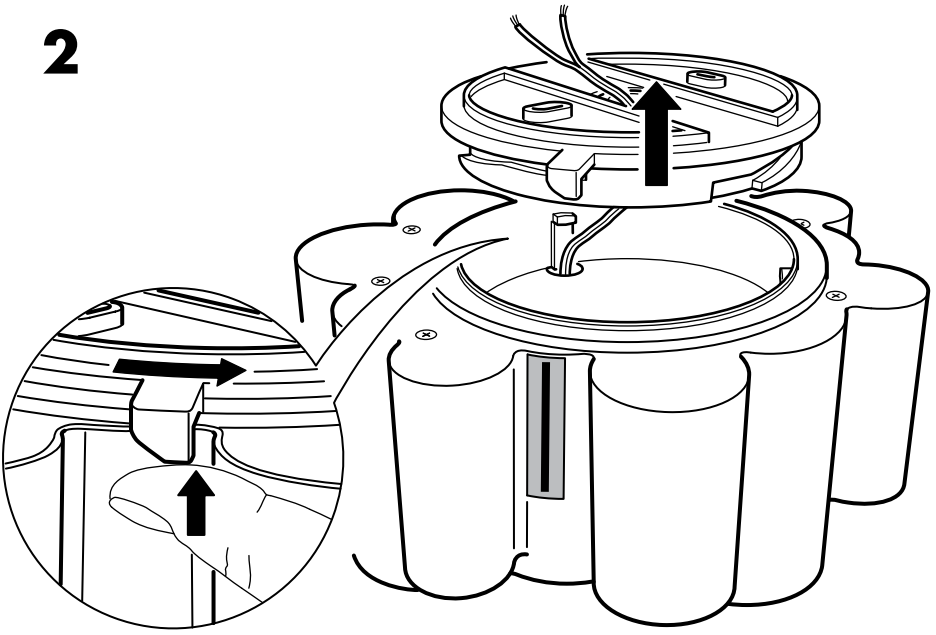

**3**



**ENGLISH**

Live

**FRANÇAIS**

Phase

**ESPAÑOL**

Con corriente.

**ENGLISH**

Neutral (with tracer)

**FRANÇAIS**

Neutre (avec orientateur)

**ESPAÑOL**

Neutro (con orientador).

**ENGLISH**

Earth/ Ground

**FRANÇAIS**

Terre

**ESPAÑOL**

Tierra

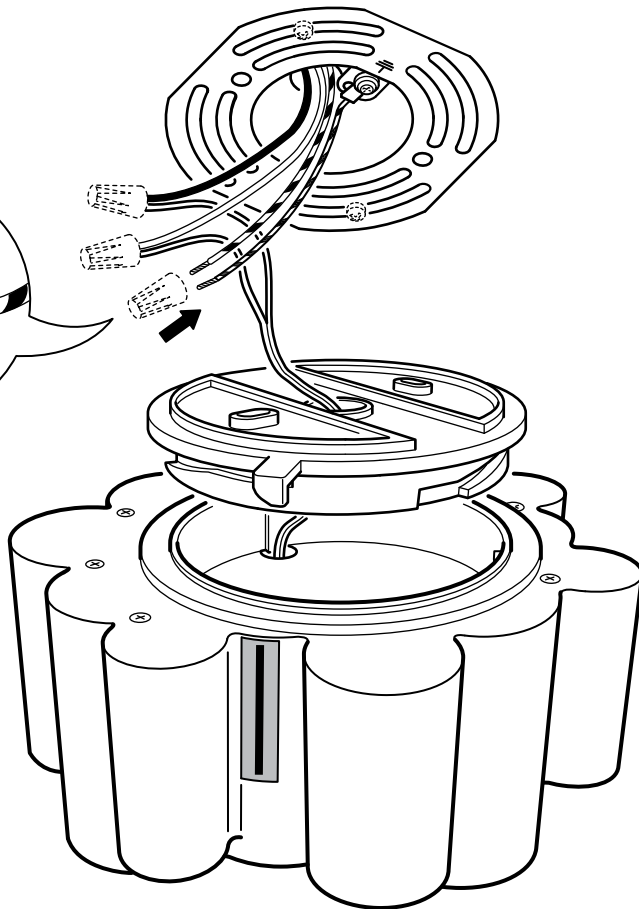
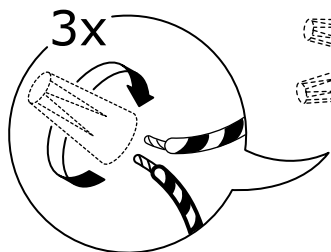
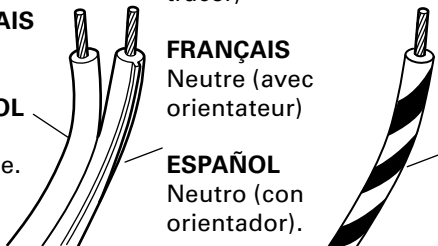

4

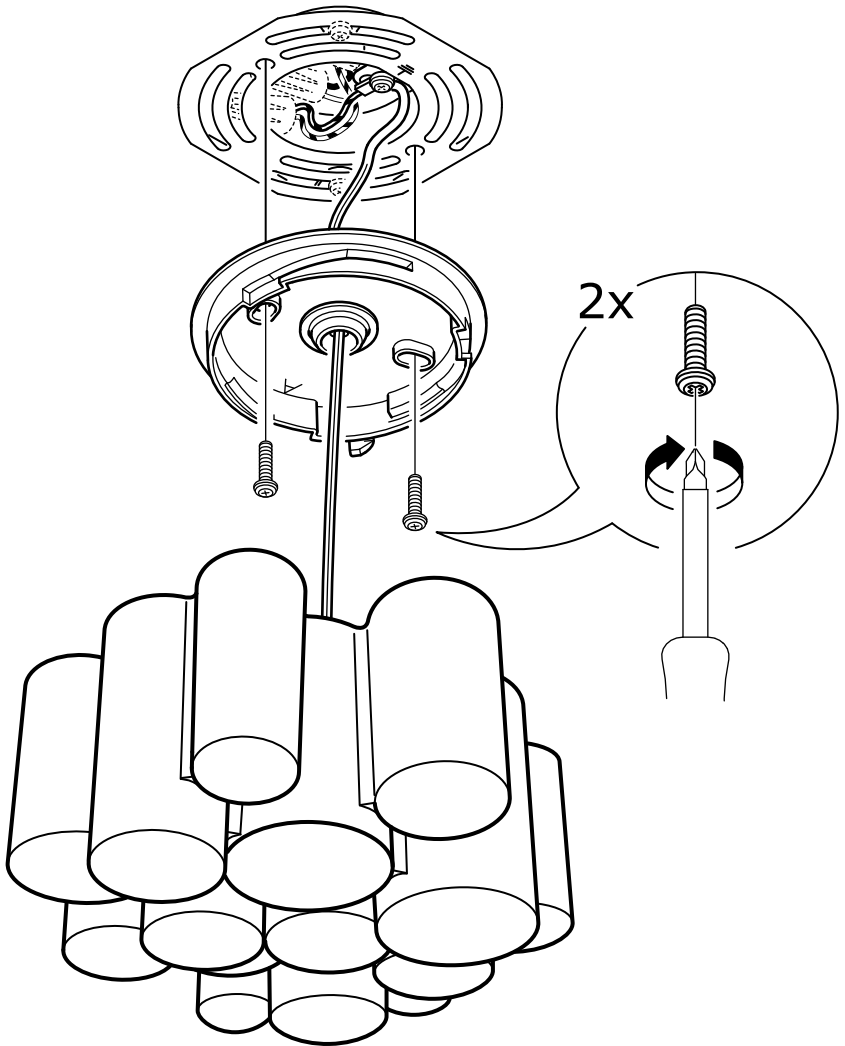

# 5

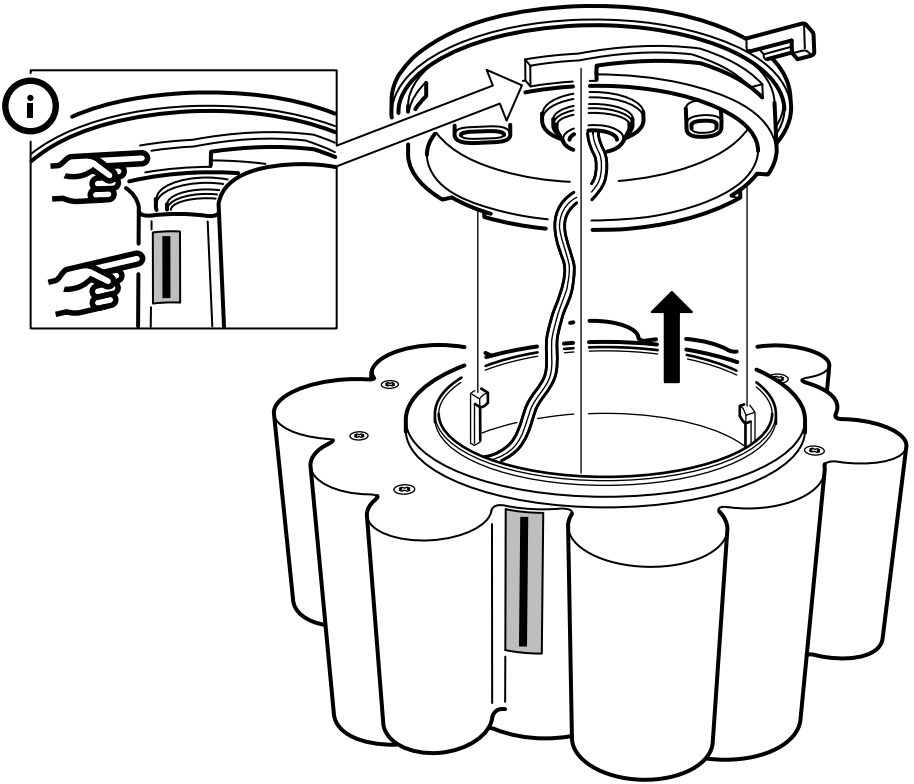



6

