

HEKTAR

GB

FR

ES

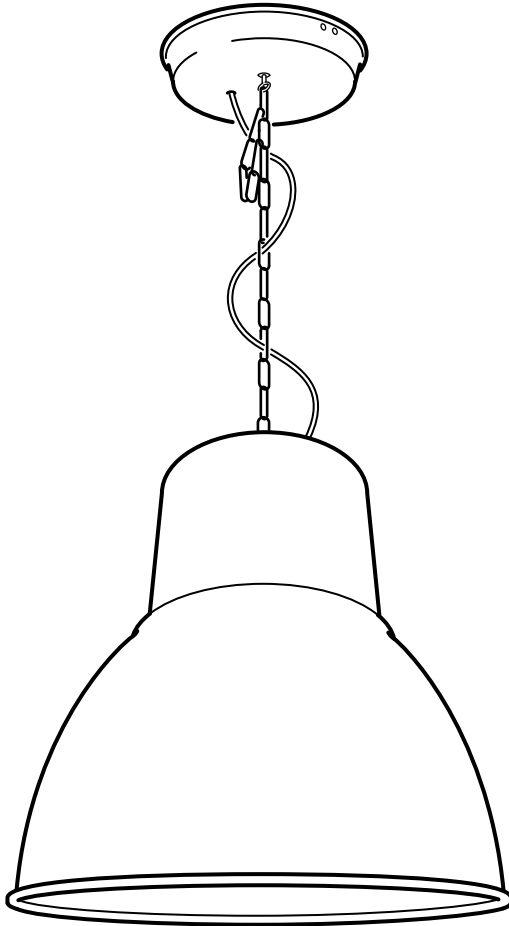

Design and Quality
IKEA of Sweden



ENGLISH
INSTALLATION INSTRUCTIONS

CAUTION:

Before starting, turn off power at main circuit panel.

FRANÇAIS
INSTRUCTIONS D'INSTALLATION

ATTENTION:

coupez l'alimentation avant de procéder à l'installation.

ESPAÑOL
INSTRUCCIONES DE MONTAJE

ADVERTENCIA:

Antes de comenzar el montaje, cortar la luz en el cuadro general.

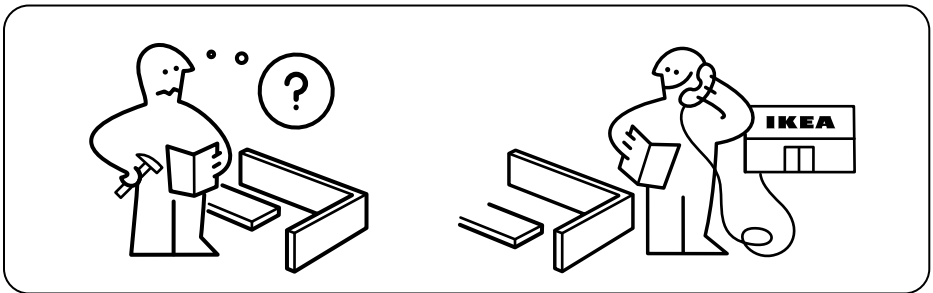
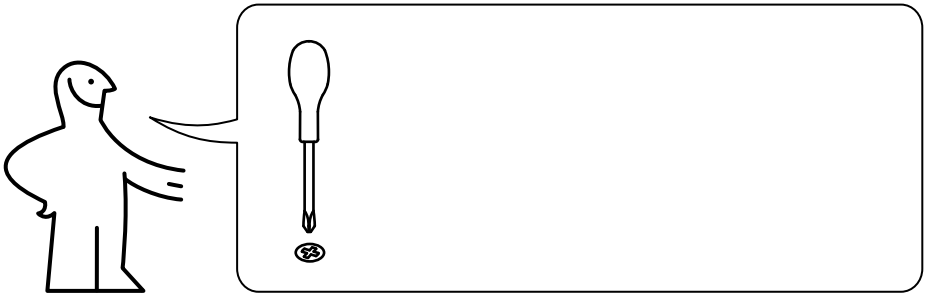



1x

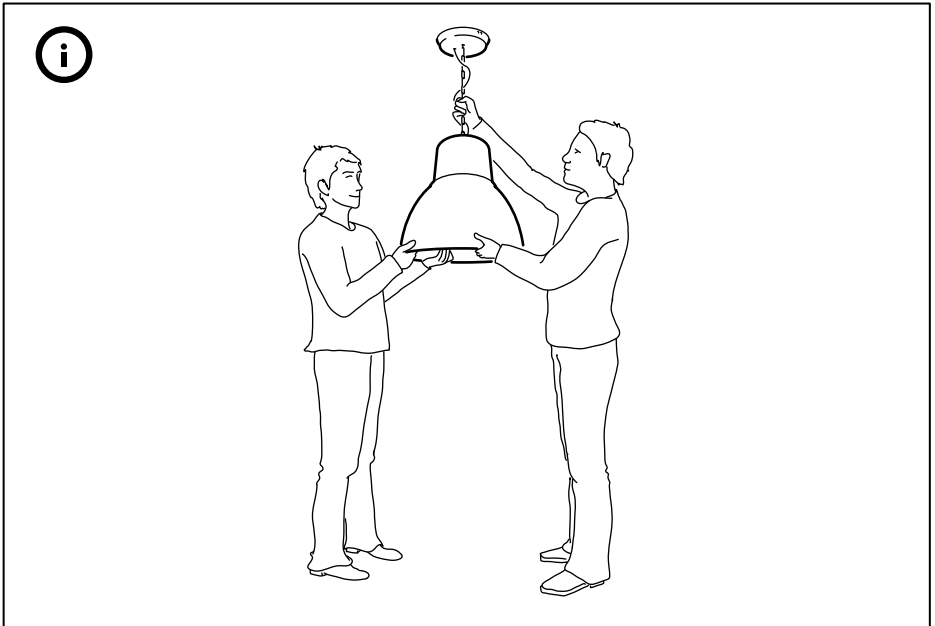

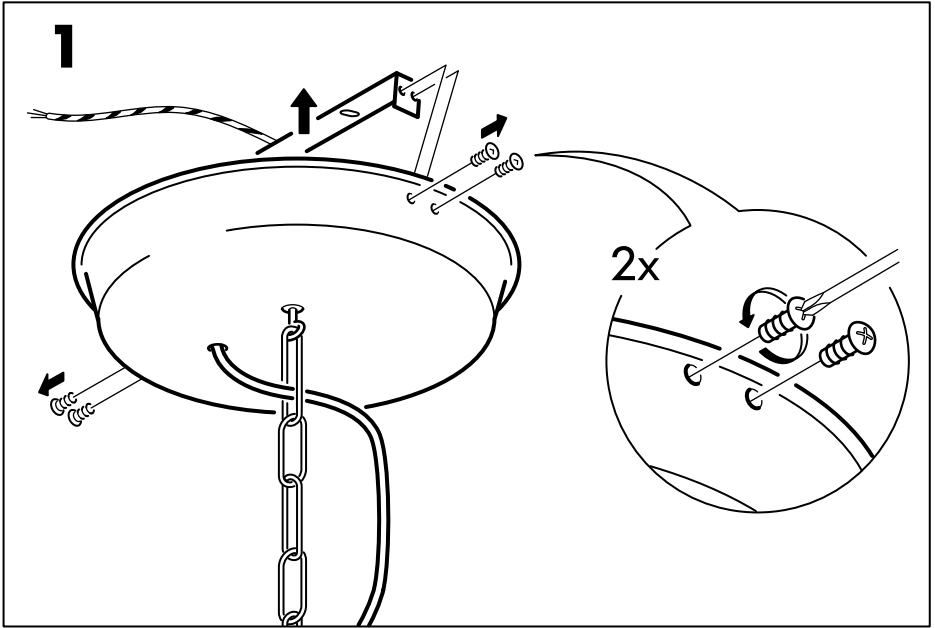

2

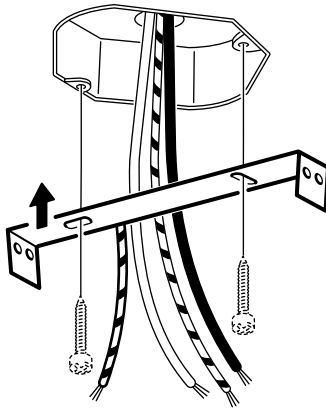

3

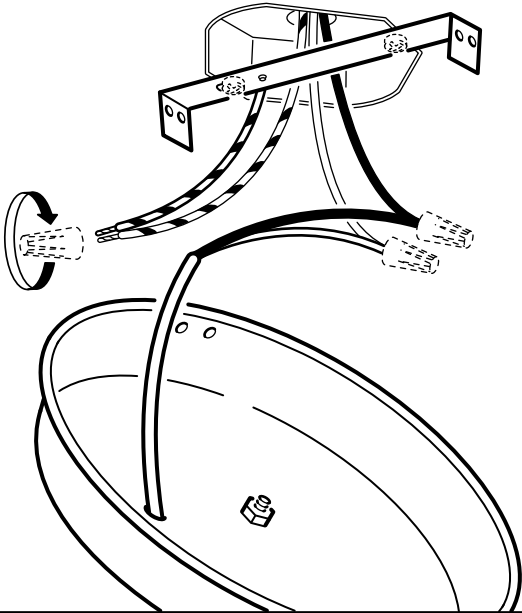

4

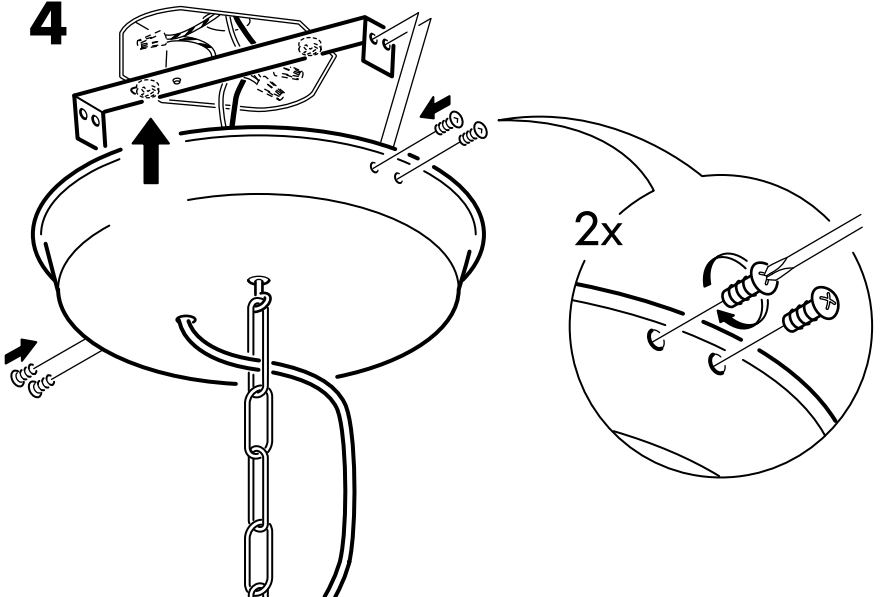

5

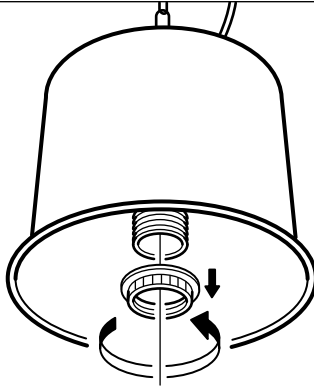

6

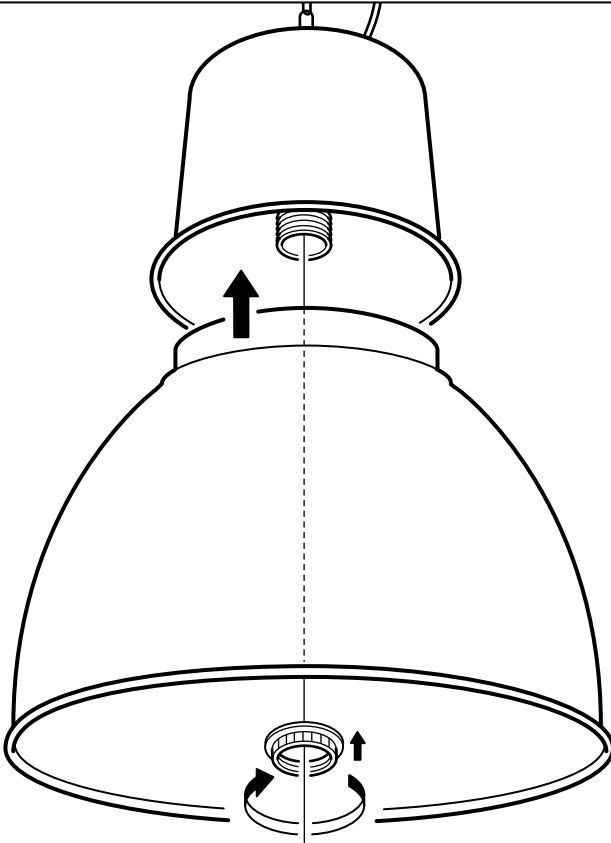



ENGLISH

The weight of the lamp must be taken by the chain. When adjusting the cable make sure that it is longer than the chain.

ESPAÑOL

La cadena debe soportar todo el peso de la lámpara. Al regular el cable, comprueba que siempre sea más largo que la cadena.

FRANÇAIS

La chaîne doit supporter tout le poids du luminaire. Lors du montage, veiller à ce que le câble soit plus long que la chaîne.

